

Mark Pruhenski
Town Manager

E-mail: mpruhenski@townofgb.org
www.townofgb.org



Town Hall, 334 Main Street
Great Barrington, MA 01230

Telephone: (413) 528-1619 x2900
Fax: (413) 528-2290

TOWN OF GREAT BARRINGTON MASSACHUSETTS

OFFICE OF THE TOWN MANAGER

Selectboard Meeting via Zoom and in person at 334 Main Street, Great Barrington, MA Order of Agenda for Monday, April 8th, 2024, at 6:00 PM

Please click this link to join the webinar:
Webinar ID: 860 4872 7526

<https://us02web.zoom.us/j/86048727526>
Dial-in, audio-only: (929) 205 6099

Pursuant to Governor Baker's March 12, 2020 Order Suspending Certain Provisions of the Open Meeting Law, G.L. c. 30A, §18, and Governor Healey's March 29, 2023 Revised Order extending remote participation by all members in any meeting of a public body, this meeting of the Selectboard will be conducted both in-person and via remote participation to the greatest extent possible. Specific information and the general guidelines for remote participation by members of the public and/or parties with a right and/or requirement to attend this meeting can be found on town's website: www.townofgb.org. Committee members and members of the public may attend this meeting in person or remotely. Instructions for remote access can be found at the top of this agenda. Every effort will be made to ensure that those attending remotely can access the proceedings in real time, via technological means.

5:15 PM: Selectboard site visit to Timberlyn Heights, 320 Maple Avenue, and Great Barrington for the Special Permit application (6b). Selectboard members only – no meeting or discussion.

1. CALL TO ORDER SELECTBOARD REGULAR MEETING (6:00 PM)
2. SELECTBOARD'S ANNOUNCEMENTS/STATEMENTS
3. APPROVAL OF MINUTES
 - a. Selectboard Minutes from February 26, 2024
 - b. Selectboard Minutes from March 11, 2024
 - c. Selectboard Minutes from March 20, 2024
4. SELECTBOARD'S ANNOUNCEMENTS/STATEMENTS
5. LICENSES AND PERMITS
 - a. Application to amend Common Victualler License – Guido's Fresh Marketplace, 760 S. Main St., Great Barrington
 - b. Application for Common Victualler License – Good Juju LLC, 70 Railroad St., Great Barrington (next to The Triplex)
 - c. Application for Common Victualler License – Bear Butter Inc., 323 Main St., Great Barrington
 - d. Application for Temporary Weekday Entertainment License – Housatonic Improvement Committee, Alice Bubriski Playground, Saturday, June 8th, 2024, 12:00 PM to 4:00 PM

- e. Application for Temporary Weekday Entertainment License – Mahaiwe Performing Arts Center Annual Gala, 52 Castle St., Great Barrington, Thursday August 1st, 2024, 4:30 PM to 8:00 PM
- f. Application for One Day Liquor License – Mahaiwe Performing Arts Center Annual Gala, 52 Castle St., Great Barrington, Thursday August 1st, 2024, 4:30 PM to 8:00 PM
- g. Application for Special Farm Winery License – Berkshire Cider Project, 58 State Road North Adams, for sale and sampling at the Great Barrington Farmers Market, 18 Church Street, beginning Saturday, May 11 until Saturday, November 9 from 9:00 AM to 1:00 PM

6. PUBLIC HEARINGS

- a. Table and Vine, Inc. Application for Multiple Amendments to Liquor License – Change of Ownership Interest (LLC Members/LLP Partners, Trustees), and Issuance/Transfer of Stock/New Stockholder at 700 Main Street 2A, Great Barrington, MA 01230
 - i. Open Public Hearing
 - ii. Explanation of the Project
 - iii. Public comments and questions, speak in favor or in opposition
 - iv. Questions from the Selectboard
 - v. Close Public Hearing
 - vi. Selectboard discussion
 - vii. Motion to continue/deny/grant
- b. Special Permit 942-24: application from Bear Mountain 320 Properties, Timberlyn Heights Care Center, to construct an addition on the existing nursing home at 320 Maple Avenue, Great Barrington, filed per Sections 3.1.4, B(10) and 10.4 of the Zoning Bylaw.
 - i. Open Public Hearing
 - ii. Explanation of the Project
 - iii. Public comments and questions, speak in favor or in opposition
 - iv. Questions from the Selectboard
 - v. Comments from other Boards
 - vi. Selectboard discussion and draft findings
 - vii. Close Public Hearing
 - viii. Motion to continue/deny/grant

7. NEW BUSINESS

- a. Cable Franchise Renewal
- b. Review and comment to the Planning Board on the Special Permit application from Zac Culbreth on behalf of Castle Street Firehouse LLC, seeking to deviate from the requirements of Section 6.4.6 of the Zoning Bylaw in order to install upward shining lights on the hose tower of the former fire station at 20 Castle Street, Great Barrington
- c. Request from Berkshire International Film Festival to hang 30” x 36” vinyl flags on Mass. Electric poles from Main St., between Pleasant St., and Bridge St., from April 22, 2024 through June 10, 2024
- d. Proposed appointment to the Cultural Council – Peggy Reeves
- e. Earth Day Clean Up Event Details

8. CITIZEN SPEAK TIME

Citizen Speak Time is an opportunity for the Selectboard to listen to residents. Topics of particular concern or importance may be placed on a future agenda for discussion. This time is reserved for town residents only unless otherwise permitted by the chair, and speakers are limited to 3 minutes each.

9. SELECTBOARD'S TIME

10. MEDIA TIME

11. ADJOURNMENT

NEXT SELECTBOARD MEETING

April 22, 2024 | April 29, 2024 | May 6, 2024 – (Annual Town Meeting) | May 9, 2024 – (Possible Continuation) | May 15, 2024 (Reorganization)



Mark Pruhenski, Town Manager

Pursuant to MGL. 7c. 30A sec. 20 (f), after notifying the chair of the public body, any person may make a video or audio recording of an open session of a meeting of a public body, or may transmit the meeting through any medium. At the beginning of the meeting, the chair shall inform other attendees of any such recordings. Any member of the public wishing to speak at the meeting must receive permission of the chair. The listings of agenda items are those reasonably anticipated by the chair, which may be discussed at the meeting. Not all items listed may in fact be discussed and other items not listed may be brought up for discussion to the extent permitted by law

COMMONWEALTH OF MASSACHUSETTS
TOWN OF GREAT BARRINGTON
APPLICATION FOR COMMON VICTUALLER LICENSE

FEE: \$25.00 (Payable to the Town of Great Barrington) DATE: 3/29/2024

NOTICE:

As provided by MGL Chapter 140, the sale of food for immediate consumption on the premises of the vendor has an intimate relation to the public health, and such activity cannot be conducted without the proper license and permit.

TO THE LICENSING AUTHORITY:

The undersigned hereby applies for a Common Victualler License in accordance with the provisions relating thereto:

OWNER(S) NAME: Luke Masiero

NAME OF BUSINESS: Guido's Quality Fruit + Produce, Inc

D/B/A (if applicable): Guido's Fresh Marketplace

BUSINESS MAILING ADDRESS: 760 S Main St, Great Barrington, MA 01230

BUSINESS TELEPHONE: 413-442-9912 HOME TELEPHONE: _____

LOCATION WHERE LICENSE IS TO BE USED: 760 S Main St

Great Barrington, MA 01230

DAYS OF OPERATION: Sunday through Saturday

HOURS OF OPERATION: 7am - 9pm

DESCRIPTION OF PREMISES: Grocery Store

Pursuant to M.G.L. Ch. 62C, Sec. 49A, I certify under the penalties of perjury that I, to my best knowledge and belief, have filed all state tax returns and paid all state taxes required under law.

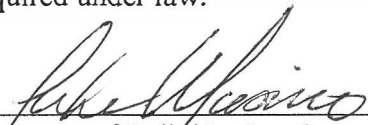
Signature of Individual or Corporate Name

By: Luke Masiero, President
Corporate Officer (if applicable)

SS# _____ or FID# 04-2722288

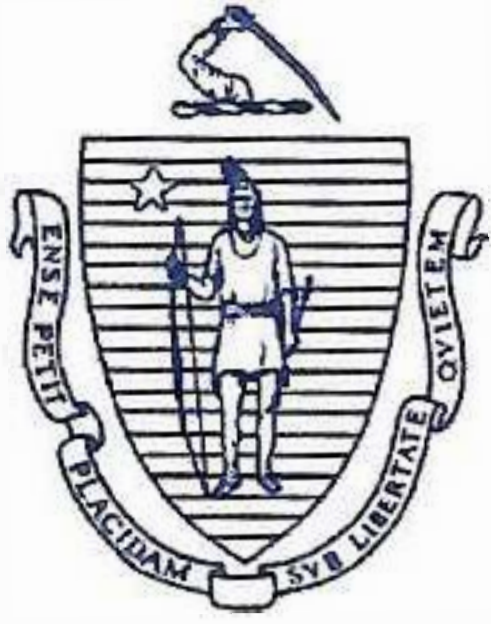

The Commonwealth of Massachusetts
Department of Industrial Accidents
 1 Congress Street, Suite 100
 Boston, MA 02114-2017
 www.mass.gov/dia

Workers' Compensation Insurance Affidavit: General Businesses.
TO BE FILED WITH THE PERMITTING AUTHORITY.

Applicant Information

Please Print Legibly

Business/Organization Name: Guido's Quality Fruit & Produce, Inc

Address: 1020 South Street

City/State/Zip: Pittsfield, MA 01201 Phone #: 413-442-9912

| | |
|--|--|
| <p>Are you an employer? Check the appropriate box:</p> <p>1. <input checked="" type="checkbox"/> I am a employer with <u>312</u> employees (full and/or part-time).*</p> <p>2. <input type="checkbox"/> I am a sole proprietor or partnership and have no employees working for me in any capacity. [No workers' comp. insurance required]</p> <p>3. <input type="checkbox"/> We are a corporation and its officers have exercised their right of exemption per c. 152, §1(4), and we have no employees. [No workers' comp. insurance required]**</p> <p>4. <input type="checkbox"/> We are a non-profit organization, staffed by volunteers, with no employees. [No workers' comp. insurance req.]</p> | <p>Business Type (required):</p> <p>5. <input checked="" type="checkbox"/> Retail</p> <p>6. <input type="checkbox"/> Restaurant/Bar/Eating Establishment</p> <p>7. <input type="checkbox"/> Office and/or Sales (incl. real estate, auto, etc.)</p> <p>8. <input type="checkbox"/> Nonprofit</p> <p>9. <input type="checkbox"/> Entertainment</p> <p>10. <input type="checkbox"/> Manufacturing</p> <p>11. <input type="checkbox"/> Health Care</p> <p>12. <input type="checkbox"/> Other _____</p> |
|--|--|

*Any applicant that checks box #1 must also fill out the section below showing their workers' compensation policy information.

**If the corporate officers have exempted themselves, but the corporation has other employees, a workers' compensation policy is required and such an organization should check box #1.

I am an employer that is providing workers' compensation insurance for my employees. Below is the policy information.

Insurance Company Name: MA Retail Merchants WC Group Inc.

Insurer's Address: PO Box 859222-9222

City/State/Zip: Braintree, MA 02185

Policy # or Self-ins. Lic. # 014005034430124 Expiration Date: 01/01/2025

Attach a copy of the workers' compensation policy declaration page (showing the policy number and expiration date).

Failure to secure coverage as required under Section 25A of MGL c. 152 can lead to the imposition of criminal penalties of a fine up to \$1,500.00 and/or one-year imprisonment, as well as civil penalties in the form of a STOP WORK ORDER and a fine of up to \$250.00 a day against the violator. Be advised that a copy of this statement may be forwarded to the Office of Investigations of the DIA for insurance coverage verification.

I do hereby certify, under the pains and penalties of perjury that the information provided above is true and correct.

Signature: *Ellen G. Am...* Date: 3/29/2024

Phone #: 413-442-9912

Official use only. Do not write in this area, to be completed by city or town official.

City or Town: _____ Permit/License # _____

Issuing Authority (circle one):

1. Board of Health 2. Building Department 3. City/Town Clerk 4. Licensing Board 5. Selectmen's Office

6. Other _____

Contact Person: _____ Phone #: _____

Workers Compensation and Employers Liability Insurance Policy

Insurer ID No (s): 34355
 MA Retail Merchants WC Group Inc.
 PO Box 859222-9222
 Braintree, MA 02185-0000

| | |
|--------------------------|--------------------------|
| Carrier Policy #: | Policy Period |
| 014005034430124 | 01/01/2024 to 01/01/2025 |

| | |
|---|---|
| Information Page | Renewal Policy |
| FEIN: 042722288 | Carrier Prior Policy #: 014005034430123 |
| Item 1: Named Insured and Address | Agency |
| Guido's Quality Fruit and Produce Inc Guido's Fresh Marketplace 1020 South Street Pittsfield, MA 01201 | Wheeler & Taylor Inc 402 East St Pittsfield, MA 01201 |

Other Workplaces Not Shown Above: See Schedule of Operations
Additional Named Insured: See Additional Named Insureds if Applicable

| | |
|-------------------------------|-------------------------|
| Type of Business: Corporation | Federal ID#: 042722288 |
| Risk ID: 124840 | NCCI / Bureau #: 34355 |
| Unemployment ID #: | File #: 014005034430124 |

Item 2. Policy Period The policy period is from 12:01 AM on 01/01/2024 to 12:01AM on 01/01/2025 based on the insured's mailing address time zone.

Item 3. Coverage:

- A. Workers Compensation Insurance: Part One of the policy applies to the Workers Compensation Law of the states listed:
 MA
- B. Employers Liability Insurance: Part Two of the policy applies to work in each state listed in Item 3.A. The limits of our liability under Part Two are:

| | | |
|---------------------------|---------------|---------------|
| Bodily Injury by Accident | \$ 500,000.00 | each accident |
| Bodily Injury by Disease | \$ 500,000.00 | policy limit |
| Bodily Injury by Disease | \$ 500,000.00 | each employee |

C. Other States Insurance:

D. This policy includes these endorsements and schedules:

WC000000C(01/15), WC000406(/), WC000414A(01/19), WC000422C(01/21), NOE(01/01), WC200102(01/14), WC200301(04/84), WC200302A(09/08), WC200303D(08/10), WC200306B(06/13), WC200405(06/01), WC200601A(07/08)

Item 4: Premium

The Premium for the policy will be determined by our Manual of Rules, Classifications, Rates and Rating Plans. All information required below is subject to verification and change by audit.

| Classifications | Code # | Premium Basis Total Estimated Annual Remuneration | Rate Per \$100 of Remuneration | Estimated Annual Premium |
|-----------------|--------|---|-----------------------------------|--------------------------|
|-----------------|--------|---|-----------------------------------|--------------------------|

See Schedule of Operations on Following Page(s)

| | | | |
|------------------------|-------------------------|---------------------------------|-------------------------|
| <u>Minimum Premium</u> | <u>Prorated Premium</u> | <u>Estimated Annual Premium</u> | <u>Expense Constant</u> |
| \$ 506.00 | \$ 77,148.00 | \$ 77,148.00 | \$ 0.00 |

Issuing Office: 35 Braintree Hill Office Park Ste 206
 Braintree MA 02185-0000

Date Printed:
 01-12-2024

Countersigned by:



Workers Compensation and Employers Liability Insurance Policy

Insurer ID No (s): 34355
 MA Retail Merchants WC Group Inc.
 PO Box 859222-9222
 Braintree, MA 02185-0000

| | |
|--------------------------|--------------------------|
| Carrier Policy #: | Policy Period |
| 014005034430124 | 01/01/2024 to 01/01/2025 |

| | |
|---|---|
| Information Page | Renewal Policy |
| FEIN: 042722288 | Carrier Prior Policy #: 014005034430123 |
| Item 1: Named Insured and Address | Agency |
| Guido's Quality Fruit and Produce Inc Guido's Fresh Marketplace 1020 South Street Pittsfield, MA 01201 | Wheeler & Taylor Inc 402 East St Pittsfield, MA 01201 |

Schedule of Covered Workplaces

Other Workplace

Guido's Quality Fruit and Produce Inc
 Guido's Fresh Marketplace
 760 Main Street
 Great Barrington, MA 01230-2014

| | |
|-----------------|------------|
| Effective Date: | 01/01/2024 |
| NAICS Code: | 445230 |
| Division #: | 0 |
| Workplace #: | 0000000002 |

Mailing:
 1020 South Street
 Pittsfield, MA 01201-8225

Workers Compensation and Employers Liability Insurance Policy

Insurer ID No (s): 34355
 MA Retail Merchants WC Group Inc.
 PO Box 859222-9222
 Braintree, MA 02185-0000

| Carrier Policy #: | Policy Period |
|-------------------|--------------------------|
| 014005034430124 | 01/01/2024 to 01/01/2025 |

| | |
|---|---|
| Information Page | Renewal Policy |
| FEIN: 042722288 | Carrier Prior Policy #: 014005034430123 |
| Item 1: Named Insured and Address | Agency |
| Guido's Quality Fruit and Produce Inc Guido's Fresh Marketplace 1020 South Street Pittsfield, MA 01201 | Wheeler & Taylor Inc 402 East St Pittsfield, MA 01201 |

Schedule of Classifications : MA

| Code No. | Classification | Payroll | Rate | Premium |
|----------|--|-----------------|------|--------------|
| 7380 | Drivers, Chauffeurs & Their He <small>01/01/24 - 01/01/25</small> | \$ 162,000.00 | 5.31 | \$ 8,602.00 |
| 8006 | Store: Grocery Retail <small>01/01/24 - 01/01/25</small> | \$ 6,800,000.00 | .80 | \$ 54,400.00 |
| 8810 | Clerical Office Employees Noc <small>01/01/24 - 01/01/25</small> | \$ 1,700,000.00 | .04 | \$ 680.00 |

| Description | Percentage | Factor | Amount |
|---|----------------------|--------|---------------------|
| Manual Premium | | | \$ 63,682.00 |
| Rate Deviation (9037) | 10.0000% | | \$ 6,368.00 |
| Increased Employers Liability Limits (9807) | 1.0000% | | \$ 573.00 |
| Experience Modification - Listed below (9898) | | 1.1900 | \$ 68,886.00 |
| Standard Premium | | | \$ 68,886.00 |
| Volume Discount (0063) | 7.7800% | | \$ 5,359.00 |
| ARAP Charge (0277) | | | \$ 11,022.00 |
| Normal Premium | | | \$ 74,549.00 |
| Expense Constant (0001) | | | \$ 0.00 |
| Domestic Terrorism (9740) | | 0.0300 | \$ 2,599.00 |
| Annual Premium | | | \$ 77,148.00 |
| DIA Assessment | 1.6200% / 1.6200% | | \$ 1,228.00 |
| Total | | | \$ 78,376.00 |

| Experience Modifiers | ARAP | Effective Date | Payroll | Rate | Charge |
|----------------------|--------|----------------|--------------|--------|----------|
| 1.1900 | 1.1600 | 01/01/2024 | 8,662,000.00 | 0.0300 | 2,599.00 |

COMMONWEALTH OF MASSACHUSETTS
TOWN OF GREAT BARRINGTON
APPLICATION FOR COMMON VICTUALLER LICENSE

FEE: \$25.00 (Payable to the Town of Great Barrington) DATE: 3/27/23

NOTICE:

As provided by MGL Chapter 140, the sale of food for immediate consumption on the premises of the vendor has an intimate relation to the public health, and such activity cannot be conducted without the proper license and permit.

TO THE LICENSING AUTHORITY:

The undersigned hereby applies for a Common Victualler License in accordance with the provisions relating thereto:

OWNER(S) NAME: Josh Irwin

NAME OF BUSINESS: Good Juju LLC

D/B/A (if applicable): Juju's

BUSINESS MAILING ADDRESS: 7 Railroad Street

BUSINESS TELEPHONE: 917 232 8477 HOME TELEPHONE: joshirwin@gmail.com

LOCATION WHERE LICENSE IS TO BE USED: 70 Railroad St

GB MA 01230 The Triplex

DAYS OF OPERATION: 7

HOURS OF OPERATION: 11 - 11

DESCRIPTION OF PREMISES: Small fast casual counter service food establishment

Pursuant to M.G.L. Ch. 62C, Sec. 49A, I certify under the penalties of perjury that I, to my best knowledge and belief, have filed all state tax returns and paid all state taxes required under law.

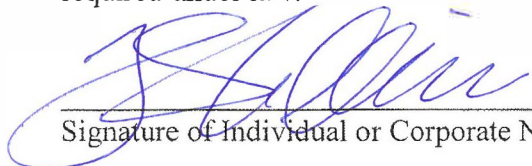
Signature of Individual or Corporate Name

By: _____
Corporate Officer (if applicable)

SS# 

or FID# 99-0425866

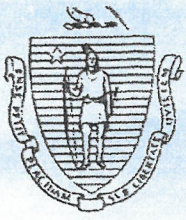

Workers' Compensation Insurance Affidavit: General Businesses

Applicant Information

Please Print Legibly

Business/Organization Name: Good Juju LLC

Address: 7 Railroad St

City/State/Zip: Great Barrington, Ma 01230 Phone #: 917-232-8477

Are you an employer? Check the appropriate box:

- I am an employer with _____ employees (full and/or part-time).*
- I am a sole proprietor or partnership and have no employees working for me in any capacity. [No workers' comp. insurance required]
- We are a corporation and its officers have exercised their right of exemption per c. 152, §1(4), and we have no employees. [No workers' comp. insurance required]**
- We are a non-profit organization, staffed by volunteers, with no employees. [No workers' comp. insurance req.]

Business Type (required):

- 5. Retail
- 6. Restaurant/Bar/Eating Establishment
- 7. Office and/or Sales (incl. real estate, auto, etc.)
- 8. Non-profit
- 9. Entertainment
- 10. Manufacturing
- 11. Health Care
- 12. Other _____

any applicant that checks box #1 must also fill out the section below showing their workers' compensation policy information. If the corporate officers have exempted themselves, but the corporation has other employees, a workers' compensation policy is required and such an organization should check box #1.

I am an employer that is providing workers' compensation insurance for my employees. Below is the policy information.

Insurance Company Name: The Hartford

Insurer's Address: On Hartford Plaza

City/State/Zip: Hartford, CT 06155

Policy # or Self-ins. Lic. #08WECBE1TVT Expiration Date: 3/15/2025

Attach a copy of the workers' compensation policy declaration page (showing the policy number and expiration date).

Failure to secure coverage as required under § 25A of MGL c. 152 can lead to the imposition of criminal penalties of a fine up to \$1,500.00 and/or one-year imprisonment, as well as civil penalties in the form of a STOP WORK ORDER and a fine of up to \$50.00 a day against the violator. Be advised that a copy of this statement may be forwarded to the Office of Investigations of the DIA for insurance coverage verification.

I do hereby certify, under the pains and penalties of perjury that the information provided above is true and correct.

Signature: [Handwritten Signature] Date: 3/27/24

Phone #: 413-770-9093

Official use only. Do not write in this area, to be completed by city or town official.

City or Town: _____ Permit/License # _____

Issuing Authority (check one):

- 1. Board of Health
- 2. Building Department
- 3. City/Town Clerk
- 4. Licensing Board
- 5. Selectmen's Office
- 6. Other _____

Contact Person: _____ Phone #: _____

COMMONWEALTH OF MASSACHUSETTS
TOWN OF GREAT BARRINGTON
APPLICATION FOR COMMON VICTUALLER LICENSE

FEE: \$25.00 (Payable to the Town of Great Barrington) DATE: 3/28/24

NOTICE:

As provided by MGL Chapter 140, the sale of food for immediate consumption on the premises of the vendor has an intimate relation to the public health, and such activity cannot be conducted without the proper license and permit.

TO THE LICENSING AUTHORITY:

The undersigned hereby applies for a Common Victualler License in accordance with the provisions relating thereto:

OWNER(S) NAME: JONATHAN VECCA

NAME OF BUSINESS: BEAR BUTTER INC

D/B/A (if applicable): _____

BUSINESS MAILING ADDRESS: 381 TYLER ST PITTSFIELD, MA 01201

BUSINESS TELEPHONE: 413-429-4509 EMAIL: US@BEARBUTTERCO.COM
HOME TELEPHONE: _____

LOCATION WHERE LICENSE IS TO BE USED: 323 MAIN ST

DAYS OF OPERATION: MON - SUN

HOURS OF OPERATION: 8-5

DESCRIPTION OF PREMISES: JUICE BAR

Pursuant to M.G.L. Ch. 62C, Sec. 49A, I certify under the penalties of perjury that I, to my best knowledge and belief, have filed all state tax returns and paid all state taxes required under law.

[Signature]
Signature of Individual or Corporate Name

By: JONATHAN VECCA (owner)
Corporate Officer (if applicable)

SS# _____ or FID# 99-2036942



The Commonwealth of Massachusetts
 Department of Industrial Accidents
 1 Congress Street, Suite 100
 Boston, MA 02114-2017
 www.mass.gov/dia

Workers' Compensation Insurance Affidavit: General Businesses.
 TO BE FILED WITH THE PERMITTING AUTHORITY.

Applicant Information

Please Print Legibly

Business/Organization Name: BEAR BUTTER INC
 Address: 381 TYLER ST
 City/State/Zip: PITTSFIELD, MA 01201 Phone #: 413-822-2520

| | |
|---|---|
| <p>Are you an employer? Check the appropriate box:</p> <p>1. <input checked="" type="checkbox"/> I am an employer with <u>5(SA)</u> employees (full and/or part-time).*</p> <p>2. <input type="checkbox"/> I am a sole proprietor or partnership and have no employees working for me in any capacity. [No workers' comp. insurance required]</p> <p>3. <input type="checkbox"/> We are a corporation and its officers have exercised their right of exemption per c. 152, §1(4), and we have no employees. [No workers' comp. insurance required]**</p> <p>4. <input type="checkbox"/> We are a non-profit organization, staffed by volunteers, with no employees. [No workers' comp. insurance req.]</p> | <p>Business Type (required):</p> <p>5. <input type="checkbox"/> Retail</p> <p>6. <input checked="" type="checkbox"/> Restaurant/Bar/Eating Establishment</p> <p>7. <input type="checkbox"/> Office and/or Sales (incl. real estate, auto, etc.)</p> <p>8. <input type="checkbox"/> Non-profit</p> <p>9. <input type="checkbox"/> Entertainment</p> <p>10. <input type="checkbox"/> Manufacturing</p> <p>11. <input type="checkbox"/> Health Care</p> <p>12. <input type="checkbox"/> Other _____</p> |
|---|---|

*Any applicant that checks box #1 must also fill out the section below showing their workers' compensation policy information.

**If the corporate officers have exempted themselves, but the corporation has other employees, a workers' compensation policy is required and such an organization should check box #1.

I am an employer that is providing workers' compensation insurance for my employees. Below is the policy information.

Insurance Company Name: THE HARTFORD

Insurer's Address: 1 HARTFORD PLAZA

City/State/Zip: HARTFORD, CT 06115

Policy # or Self-ins. Lic. # 08WECAL551D Expiration Date: 4/30/24 (RENEWS)

Attach a copy of the workers' compensation policy declaration page (showing the policy number and expiration date).

Failure to secure coverage as required under Section 25A of MGL c. 152 can lead to the imposition of criminal penalties of a fine up to \$1,500.00 and/or one-year imprisonment, as well as civil penalties in the form of a STOP WORK ORDER and a fine of up to \$250.00 a day against the violator. Be advised that a copy of this statement may be forwarded to the Office of Investigations of the DIA for insurance coverage verification.

I do hereby certify, under the pains and penalties of perjury that the information provided above is true and correct.

Signature: [Signature] Date: 4/2/24

Phone #: 413-822-2520

| | |
|---|------------------------|
| <i>Official use only. Do not write in this area, to be completed by city or town official.</i> | |
| City or Town: _____ | Permit/License # _____ |
| Issuing Authority (circle one): | |
| 1. Board of Health 2. Building Department 3. City/Town Clerk 4. Licensing Board 5. Selectmen's Office | |
| 6. Other _____ | |
| Contact Person: _____ | Phone #: _____ |



TOWN OF GREAT BARRINGTON
Temporary Weekday Entertainment License Application
\$25.00 per day

The undersigned hereby applies for a license in accordance with the provisions of MA General Laws, Ch.140 Sec.183A amended, Ch.351, Sec.85 of Acts of 1981 and Ch.140 Sec.181.

Name: Angela Lomanto, Chair

Business/Organization: Housatonic Improvement Committee

D/B/A (if applicable): _____

Address: c/o Town Hall

Mailing Address: _____

Phone Number: 413 717 8295

Email: angela.lomanto@gmail.com

TYPE: (Check all that apply) Concert Dance Exhibition Cabaret DJ

Live band with up to ___ pieces, including singers Public Show

Other (please explain) Community Party

INCLUDES: Live music Recorded music Dancing by entertainers/ performers

Dancing by patrons Amplification system Theatrical exhibition

Floorshow Play Moving picture show Light show Jukebox

Other (please explain) food trucks, facepainting

As part of the entertainment, will any person be permitted to appear on the premises in any manner or attire as to expose to public view any portion of the pubic area, anus, or genitals, or any simulation thereof, or whether any person will be permitted to appear on the premises in any manner or attire as to expose to public view a portion of the breast below the top of the areola, or any simulation thereof? (M.G.L.Chp.140 Sec.183A)

___ YES

X NO

Please circle: INDOOR or **OUTDOOR** Entertainment

Exact Location of Entertainment (include sketch): Alice Bubriski Playground, layout TBD

Date(s) of Entertainment*: Saturday, June 8, 2024

*Does not include SUNDAY

Start & End Times of Entertainment: 12 - 4 pm

Does your event involve any of the following? (Check all that apply)

- Food
- Temporary Bathrooms
- Tents
- Stages
- Temporary Signs
- Electrical Permits
- Building Permits
- Police Traffic Details
- Street Closures

ALL entertainment licenses will be reviewed by the Design Review Team (DRT), which is comprised of several Town departments, for comments/concerns on this application.

Pursuant to M.G.L. Ch. 62C, Sec. 49A, I certify under the penalties of perjury that I, to my best knowledge and belief, have filed all state tax returns and paid all state taxes required under law.

Angela Amato
 Signature of Individual or
 Corporate Officer

3/28/24
 Date

TOWN USE ONLY:

DRT Review with Conditions: Any food must be coordinated with the Health Department at least 4 weeks in advance. (CP)

APPROVAL DATE: _____

LICENSE # _____



TOWN OF GREAT BARRINGTON
Temporary Weekday Entertainment License Application
\$25.00 per day

The undersigned hereby applies for a license in accordance with the provisions of MA General Laws, Ch.140 Sec.183A amended, Ch.351, Sec.85 of Acts of 1981 and Ch.140 Sec.181.

Name: Janis Martinson

Business/Organization: Mahaiwe Performing Arts Center

D/B/A (if applicable): _____

Address: 244 Main St., Great Barrington MA 01230

Mailing Address: PO Box 690

Phone Number: 413-644-9040 x106

Email: janis@mahaiwe.org

TYPE: (Check all that apply) Concert Dance Exhibition Cabaret DJ
 Live band with up to ___ pieces, including singers Public Show
 Other (please explain) recorded music played at low volume

INCLUDES: Live music Recorded music Dancing by entertainers/ performers
 Dancing by patrons Amplification system Theatrical exhibition
 Floorshow Play Moving picture show Light show Jukebox
 Other (please explain) spoken remarks through PA system

As part of the entertainment, will any person be permitted to appear on the premises in any manner or attire as to expose to public view any portion of the pubic area, anus, or genitals, or any simulation thereof, or whether any person will be permitted to appear on the premises in any manner or attire as to expose to public view a portion of the breast below the top of the areola, or any simulation thereof? (M.G.L.Chp.140 Sec.183A)

___ YES X NO

Please circle: INDOOR or OUTDOOR Entertainment

Exact Location of Entertainment (include sketch): _____

52 Castle Street, Great Barrington

Date(s) of Entertainment*: **August 1, 2024**

***Does not include SUNDAY**

Start & End Times of Entertainment: **4:30 - 8:00 pm**

Does your event involve any of the following? (Check all that apply)

- Food Temporary Bathrooms Tents Stages Temporary Signs
- Electrical Permits Building Permits Police Traffic Details Street Closures

ALL entertainment licenses will be reviewed by the Design Review Team (DRT), which is comprised of several Town departments, for comments/concerns on this application.

Pursuant to M.G.L. Ch. 62C, Sec. 49A, I certify under the penalties of perjury that I, to my best knowledge and belief, have filed all state tax returns and paid all state taxes required under law.

Janis Martin
Signature of Individual or
Corporate Officer

3/28/24
Date

TOWN USE ONLY:

DRT Review with Conditions: _____

Staff notes this is the same date and time as the Firefighters Car Show downtown. Staff has significant concerns with regards to traffic, parking, and emergency coordination, and suggests that the Selectboard require the organizers of both events meet together with staff to discuss and coordinate.

APPROVAL DATE: _____

LICENSE # _____

March 31st, 2024

Board of Selectmen
Town Hall
Great Barrington, Mass.
01230

Dale Culleton—manager
Alder Creek LLC
212 North Plain Road
Great Barrington, Mass. 01230

To the Select Board of Great Barrington,

I am writing to grant permission to the Mahaiwe Performing Arts Center to occupy our property at 52 Castle Street for their fundraising Gala on August 1, 2024. I am aware of the fact that they will have a cocktail hour and dinner served during the event.

We are fine with the dates of the tent being on the property from July 31, 2024 through the following Monday August 5. Insurance and indemnification shall apply.

Best regards, Dale Culleton—manager Alder Creek LLC

 3-31-2024

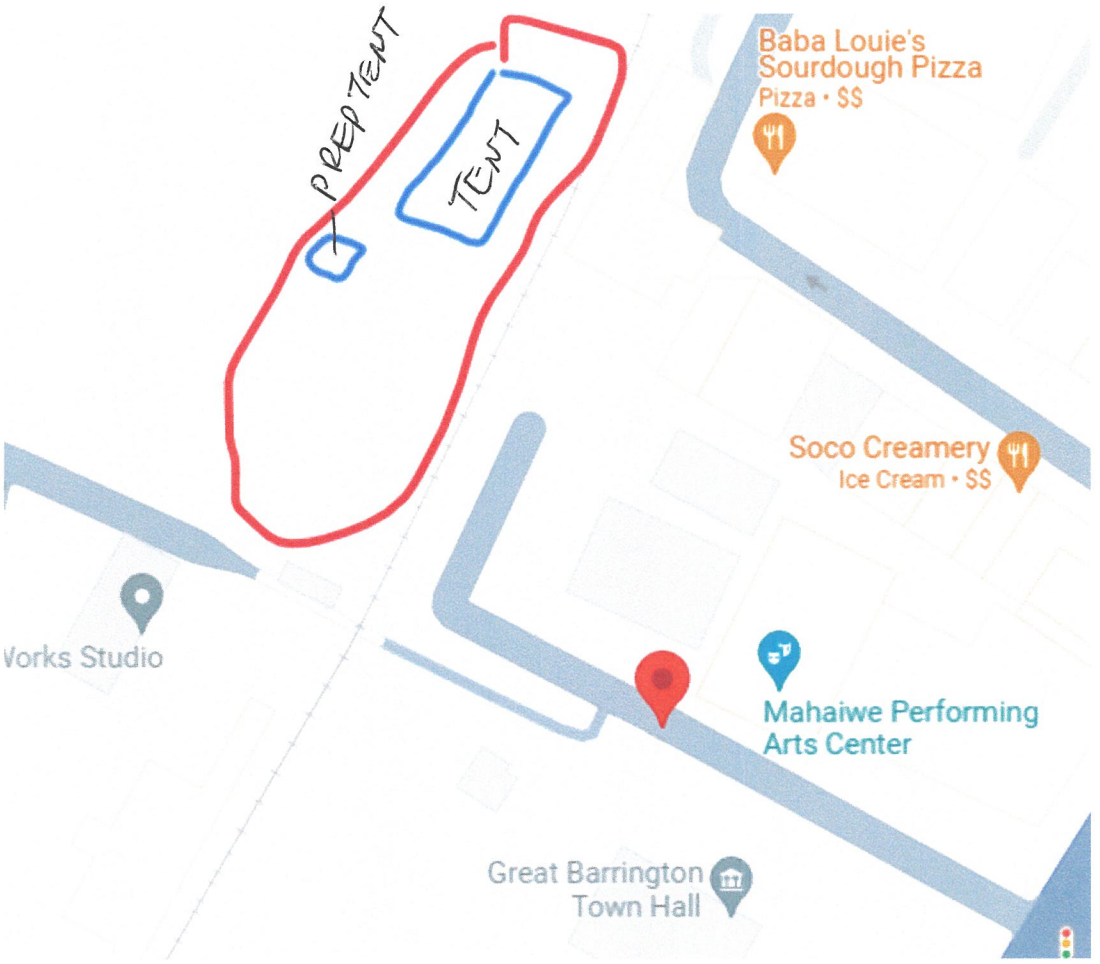

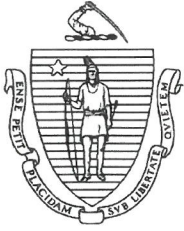

The Commonwealth of Massachusetts
Department of Industrial Accidents
1 Congress Street, Suite 100
Boston, MA 02114-2017
www.mass.gov/dia

Workers' Compensation Insurance Affidavit: General Businesses.
TO BE FILED WITH THE PERMITTING AUTHORITY.

Applicant Information

Please Print Legibly

Business/Organization Name: Mahaiwe Performing Arts Center, Inc.

Address: 244 Main Street - PO Box 690

City/State/Zip: Great Barrington MA 01230 Phone #: 413-644-9040

Are you an employer? Check the appropriate box:

- 1. [X] I am an employer with 30 employees (full and/ or part-time).*
2. [] I am a sole proprietor or partnership and have no employees working for me in any capacity. [No workers' comp. insurance required]
3. [] We are a corporation and its officers have exercised their right of exemption per c. 152, §1(4), and we have no employees. [No workers' comp. insurance required]**
4. [] We are a non-profit organization, staffed by volunteers, with no employees. [No workers' comp. insurance req.]

Business Type (required):

- 5. [] Retail
6. [] Restaurant/Bar/Eating Establishment
7. [] Office and/or Sales (incl. real estate, auto, etc.)
8. [X] Non-profit
9. [] Entertainment
10. [] Manufacturing
11. [] Health Care
12. [] Other

*Any applicant that checks box #1 must also fill out the section below showing their workers' compensation policy information.

**If the corporate officers have exempted themselves, but the corporation has other employees, a workers' compensation policy is required and such an organization should check box #1.

I am an employer that is providing workers' compensation insurance for my employees. Below is the policy information.

Insurance Company Name: Employers Assurance Co

Insurer's Address: PO Box 539003

City/State/Zip: Henderson NV 89053-9003

Policy # or Self-ins. Lic. # EIG 4913618 02 Expiration Date: 01/25/2025

Attach a copy of the workers' compensation policy declaration page (showing the policy number and expiration date).

Failure to secure coverage as required under Section 25A of MGL c. 152 can lead to the imposition of criminal penalties of a fine up to \$1,500.00 and/or one-year imprisonment, as well as civil penalties in the form of a STOP WORK ORDER and a fine of up to \$250.00 a day against the violator. Be advised that a copy of this statement may be forwarded to the Office of Investigations of the DIA for insurance coverage verification.

I do hereby certify, under the pains and penalties of perjury that the information provided above is true and correct.

Signature: [Handwritten Signature] Date: 3/26/24

Phone #: 413-644-9040 x108

Official use only. Do not write in this area, to be completed by city or town official.

City or Town: Permit/License #

Issuing Authority (circle one):

- 1. Board of Health 2. Building Department 3. City/Town Clerk 4. Licensing Board 5. Selectmen's Office
6. Other

Contact Person: Phone #:



EMPLOYERS ASSURANCE CO.
A Stock Company

Workers' Compensation and Employers Liability
Insurance Policy

| | | |
|--|---------------|------------|
| Policy Number | Policy Period | |
| | From | To |
| EIG 4913618 02 | 01/25/2024 | 01/25/2025 |
| 12:01A.M. Standard Time at the address of the Insured as stated herein | | |

Transaction

RENEWAL DECLARATIONS

NCCI Carrier # 36870 WCIRB CARRIER# PRIOR POLICY NUMBER EIG491361801

| | |
|---|--|
| 1. Named Insured and Address | Agent |
| MAHAIWE PERFORMING ARTS CENTER PO BOX 690 GREAT BARRINGTON MA 01230 | MAURY DONNELLY & PARR INC 33 SOUTH GAY STREET BALTIMORE, MD 21202 Telephone: 4105473188 |
| | 0001666 |

| | | | | |
|------------|--------------------|---------------------|-----------|----------------------------------|
| Customer # | Carrier # 36870 | FEIN # 571140453 | Risk ID # | Entity of Insured CORPORATION |
|------------|--------------------|---------------------|-----------|----------------------------------|

Additional Locations:

- 2. The Policy Period is from 01/25/2024 to 01/25/2025 12:01 a.m. Standard Time at the Insured's mailing address.
- 3. A. Workers Compensation Insurance: Part ONE of the policy applies to the Workers Compensation Law of the states listed here: MA, NY
- B. Employers Liability Insurance: Part TWO of the policy applies to work in each state listed in Item 3A. The limits of our liability under Part TWO are:

| | | | |
|---------------------------|----|-----------|---------------|
| Bodily Injury by Accident | \$ | 1,000,000 | each accident |
| Bodily Injury by Disease | \$ | 1,000,000 | policy limit |
| Bodily Injury by Disease | \$ | 1,000,000 | each employee |
- C. Other States Insurance: Part THREE of the policy applies to the states, if any, listed here: All states except ND, OH, WA, WY and states listed in item 3.A.
- D. This policy includes these endorsements and schedules: See attached schedule.
- 4. The premium for this policy will be determined by our Manuals of Rules, Classifications, Rates, and Rating Plans. All information required below is subject to verification and change by audit.

SEE EXTENSION OF INFORMATION PAGE

| | | | | | |
|-----------------------|----|-----|--------------------------------|----|-------|
| Minimum Premium | \$ | 233 | Expense Constant | \$ | 338 |
| | | | Premium Discount | \$ | |
| Assessments and Taxes | \$ | | Total Estimated Annual Premium | \$ | 4,501 |

This is a Three Year Fixed Rate Policy
Premium Adjustment Period: Annual; Semiannual; Quarterly; Monthly

Countersigned this Day of

Issued Date: 12/18/2023

Issuing Office EMPLOYERS ASSURANCE CO.
P.O. BOX 539003
HENDERSON, NV 89053-9003

Authorized Representative

Issued Date 12/18/2023
WC990630 (5/98 Ed.)

INSURED COPY

Fee: \$25.00 (per day)



APPLICATION FOR ONE DAY LIQUOR LICENSE

TO THE LICENSING AUTHORITY:

The undersigned hereby applies for a License in accordance with the provisions relating thereto:

Applicant's Name: Janis Martinson

Organization Name: Mahaiwe Performing Arts Center

Applicant's Address: 244 Main St, Great Barrington MA

Telephone Number: 413-644-9040 x106

Type of License: **ONE DAY BEER & WINE** **ONE DAY ALL ALCOHOLIC**
(Circle one)

Event: Annual Gala

Date: 8/1/24 Start Time: 4:00pm End Time: 8:00pm

Event Address: 52 Castle street

Is the Event on Town property? **YES** **NO**

PLEASE ATTACH THE FOLLOWING TO YOUR APPLICATION:

1. TIPS or ServSafe Alcohol certification for anyone serving alcohol.
2. Certificate of Insurance showing proof of Liquor Liability coverage.
(If the event is on Town property, the certificate must name the Town of Great Barrington as additional insured.)
3. If the event is not on applicant's property, a letter of permission from the owner is required.

Liability: The below individual agrees to take responsibility for the above-noted event and further agrees to indemnify, save harmless, and defend the Town of Great Barrington, its officers, employees and agents, from and against any and all liabilities, claims, penalties, forfeitures, suits, and the costs and expenses incident thereto, which may occur in connection with this event.

Janis Martinson
Signature of Applicant

3/28/24
Date

FOR TOWN USE:

Approved _____ Denied _____ Postponed _____

This is your official TIPS certification card. Carry it with you as proof of your TIPS certification.

Congratulations!

This card certifies that you have successfully completed the TIPS (Training for Intervention ProcedureS) program. We value your participation and dedication to the responsible sale, service, and consumption of alcohol.

By using the techniques you have learned, you will help to provide a safer environment for your patrons, peers, and colleagues and reduce the tragedies resulting from intoxication, underage drinking, and drunk driving.

If you have any information you think would enhance the TIPS program, or if we can assist you in any way, please contact us at 800-438-8477.



Sincerely,
Adam Chafetz
Adam F. Chafetz
HCI President

ID#: 5534309 Name: Peter R Platt
Exam Date: 8/17/2021 Expiration Date: 8/17/2024

TIPS eTIPS On Premise 3.1 **CERTIFIED**
Issued: 8/17/2021 Expires: 8/17/2024
ID#: 5534309

Peter R Platt
The Old Inn On The Green
134 Hartsville New Marlboro Rd
New Marlborough, MA 01230-2159

For service visit us online at www.gettips.com



March 31st, 2024

Board of Selectmen
Town Hall
Great Barrington, Mass.
01230

Dale Culleton—manager
Alder Creek LLC
212 North Plain Road
Great Barrington, Mass. 01230

To the Select Board of Great Barrington,

I am writing to grant permission to the Mahaiwe Performing Arts Center to occupy our property at 52 Castle Street for their fundraising Gala on August 1, 2024. I am aware of the fact that they will have a cocktail hour and dinner served during the event.

We are fine with the dates of the tent being on the property from July 31, 2024 through the following Monday August 5. Insurance and indemnification shall apply.

Best regards, Dale Culleton—manager Alder Creek LLC

 3-31-2024

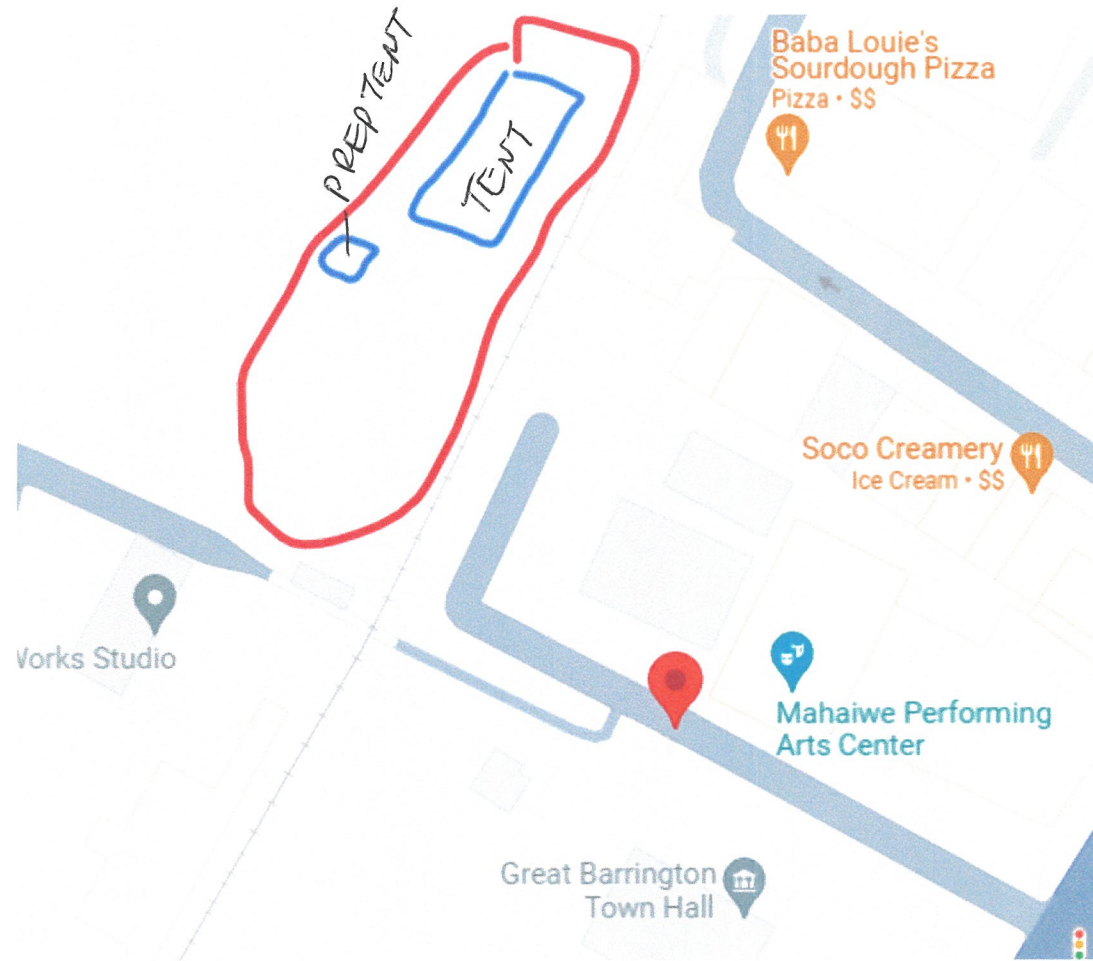

THE COMMONWEALTH OF MASSACHUSETTS
EXECUTIVE OFFICE OF ENERGY AND ENVIRONMENTAL AFFAIRS



Department of Agricultural Resources
100 Cambridge Street, 9th Floor, Boston, MA 02114
www.mass.gov/agr



Maura T. Healey
GOVERNOR

Kimberley Driscoll
LIEUTENANT
GOVERNOR

Rebecca L. Tepper
SECRETARY

Ashley E. Randle
COMMISSIONER

3/22/2024

Katherine Hand
Berkshire Cider Project
508 State Rd North Adams,
MA 01247

Dear Katherine Hand,

Please be advised that your application for certification of the Great Barrington Farmers Market occurring on Saturday 5/11/2024 through Saturday 11/9/2024 between the hours of 09:00 AM to 01:00 PM as an agricultural event pursuant to M.G.L.c. Section 15F has been approved.

Please remember that, upon certification of an agricultural event by MDAR, the farm-winery must submit a copy of the approved application to the local licensing authority along with the application for obtaining a special license from the city or town in which the event will be held. Upon issuance of a special license, the winery should confirm that a copy of the special license was sent by the local licensing authority to the Alcoholic Beverages Control Commission (ABCC) at least seven (7) days prior to the event.

A handwritten signature in blue ink that reads "Ashley E. Randle".

Ashley E. Randle, Commissioner

1. Applicant information

Name of Licensed Farm-Winery: Berkshire Cider Project

Farm-Winery License Number: FW-LIC-000170

State of Issue: Massachusetts

Contact Person: Katherine Hand

Address:

508 State Rd
Berkshire Cider Project, Greylock W
North Adams, MA 01247

Phone Number: 19144561880

Email: berkshireciderproject@gmail.com

Correspondence preference: Email

Do you intend to sell, sample, or both?

Sell

Sample

2. Event Information

Name of Agricultural Event: Great Barrington Farmers Market

Type of Event: Farmers Market (as defined by MDAR policy)

If you selected "Other Agricultural Event", how does this event promote local agriculture?

Event Address:

18 Church St.
Great Barrington, MA 01230

Event Phone Number: 413-645-4685

Event Website: <https://www.greatbarringtonfarmersmarket.org/>

3. Event Description

What are the date(s) and time(s) of the event?

If this is a weekly event, on what day of the week does the event occur?

Start date: 05/11/24

End date: 11/09/24

Time: 09:00 AM

If this is a weekly event, on what day of the week does the event occur? Saturday

If the event is an agricultural fair, does the event include competitive agriculture? N/A

Is the event sponsored or run by an agricultural/horticultural society, grange, agricultural commission or association whose primary purpose is the promotion of agriculture and its allied industries?

No

4. Event Management

Name of Event Manager: Dennis Iodice

Email Address: DennisIodice@Gmail.com

Phone Number: (413) 645-4685

Is this person the on-site manager? Yes

If no, identify on-site manager (include contact information):

If there are multiple managers, list them and include contact information

Attach on-site manager(s) resume(s) or list any credentials or training of the on-site manager(s):

https://massgov-my.sharepoint.com/:b:/g/personal/michael_w_orcutt_mass_gov/EQXmvpqllloJGimlI5ZF72cBX7ka2ra53X3Oc6rjAOWKnQ?name=/119598775_DennisIodiceResume.pdf

General

Attach a plan depicting the premises and the specific location where the license will be exercised.

https://massgov-my.sharepoint.com/:i:/g/personal/michael_w_orcutt_mass_gov/Eck4z5u_mK5NqYVBXWFa7gYB6c1gtxujSETTeSWg8thJ8w?name=/119598994_Screenshot20240316at3.45.09PM.png

Signature of Applicant

I hereby certify that all information provided in connection with this application, including all attachments, is true, accurate, and complete to the best of my knowledge under the penalties of perjury. I further understand that any falsification, omission, or concealment of material fact may result in the denial of this application and further legal action by the Department.

Date: 3/19/24

Name: Katherine Hand

Title: Owner

Farm-Winery License Number: 170

State: MA

For Department use only

Approval:

The event listed above is an approved agricultural event by the Massachusetts Department of Agricultural Resources under M.G.L. C138, Sec. 15F.

Signature:

Ashley E. Randle

Date: 3/22/24



Rich text editor toolbar with icons for search, undo, redo, print, undo, redo, 100%, Normal text, Times..., font size (10), bold (B), italic (I), underline (U), text color (A), link, insert, list, bulleted list, numbered list, indent, outdent, and zoom in.



IMPORTANT! PLEASE RETAIN THESE RULES FOR FUTURE REFERENCE!

GREAT BARRINGTON FARMERS' MARKET RULES AND REGULATIONS 2024 SEASON

PREFACE

We, The Great Barrington Farmers' Market, are a group of local farmers, food producers, and crafts people who have joined together to offer a weekly outdoor market to the people of the Great Barrington area.

Now entering our 34th year, the GBFM has always operated to promote locally grown and locally produced products. It is the belief of the GBFM that increased consumption of locally produced goods strengthens local farms and small businesses, improves the local economy, helps to develop community, and brings quality products and enjoyment to local consumers.

As a grower/producer market we take our commitment seriously that we as individuals and as a market are an integral part of a healthy local food system and that we offer for sale at the market only items which we have personally grown or produced.

The only exception is for those local items, deemed necessary by the steering committee, for which we have been unable to procure the actual grower/producer and for which we feel the market as a whole would be greatly enhanced. For further details see Section I Definitions, L, below.

All members of the GBFM are expected to take an active part in the market community. To that end, they are expected to volunteer their time and energy to aid in the successful operation of the market and to attend monthly on-site market meetings when invited.

Section I: Definitions

Please notice that the Great Barrington Farmers' Market (GBFM) is a 100% participating vendor' grown and/or produced market.

The following definitions contain requirements and are approved by the Great Barrington Farmers' Market (GBFM).

- A. CONTROLLED LAND – real property that is either: owned, rented, or leased by the farm.
- B. CUSTOM WORK – that labor which is not performed by the vendor or his/her regular help, but by another



Go pageless by default

Save time formatting by making pageless your default for every new document. Change this any time by selecting **Page setup** in the **File** menu. [Learn more](#)

[Dismiss](#)

[Set as default](#)



VENDOR CANCELLATION POLICY:

Seasonal vendors are allowed 3 timely cancellations per season.

Rotational vendors are allowed 1 timely cancellation per season.

- A cancellation is considered timely if a vendor notifies the Market manager 7 full calendar days or more that they need to cancel.
- If a seasonal or rotational vendor exceeds their allotted cancellations, they risk being moved to the vendor waitlist or removed completely from the Market without a refund at the sole discretion of the Market manager.
- Notifications within 6 calendar days or less is considered a late cancellation and the vendor will be assessed a non-negotiable, non-refundable \$150 fee. Food truck fee is \$300.
- Covid is not a valid reason for late cancellation. It is expected that you have adequate staffing, relatives, or friends that are able to work your booth in your absence at any point for any reason during the Market season.

WEATHER CANCELLATION POLICY AND REFUNDS:

The SoWa Open Market is a "rain or shine" event.

- A complete closure, or early closure of any Open Market date will be at the sole discretion of SoWa Boston. It is unusual for us to cancel a Market date unless extreme weather conditions are forecasted.
- Vendors will be notified via email on Saturday afternoon if the Sunday Market is to be canceled due to imminent inclement weather.
- If we cancel a Market date, rotating vendors will receive a refund in the amount of the daily rate. If we close a Market early, rotational vendors will receive a refund based on a prorated hourly rate.
- If we cancel a Market date or close a Market early, seasonal vendors will not receive a refund for the day; seasonal vendors already receive a discounted rate.

VENDOR BOOTH LOCATION:

SoWa Market management determines vendor booth location for each Market.

- Vendors will receive a weekly email with the Sunday Market map and booth number assignments.

- Market management will prioritize keeping seasonal vendors in the same booth space throughout the season; although management maintains the right to shift vendors as necessary.
- Booth sharing is not permitted unless special permission is granted by Market management.

VENDOR SETUP AND BREAK DOWN PROCEDURE:

All vendors must be setup and fully operational by 10:30am.

- Vendors may drive into the 500 Harrison Ave lot and unload near their booth location.
- SoWa staff will be onsite to help direct you to your booth location if you need it; booth spaces will be marked and numbered.
- Vendors must unload, then promptly remove their vehicle from the lot BEFORE returning to setup. This is for safety, to alleviate traffic jams, and to ensure all vehicles are out of the lot prior to Open Market hours.
- Vendors must provide their own handcarts and dollies if needed.
- Vendors are responsible for cleaning their surrounding area, including the removal of all trash and debris at the close of each Market.
- Early breakdown is not permitted.
- Vendors should completely breakdown BEFORE bringing vehicles into the lot to load out.
- All vendors should be completely vacated before 6:00pm.

TENTS AND EQUIPMENT:

All Vendors must supply their own 10'x10' white tent and all necessary displays, signs, tables, point of sale systems, and other equipment.

- For everyone's safety, all tents must be secured with 40 pound weight bags on EACH tent leg (160lbs total) for the duration of each Market.
- To create a uniform Market aesthetic, we ask that all vendors use white tent frames and tops. Branding/logos are permitted, as long as the tent cover itself is white or light/neutral.
- Other colors may be considered on a case-by-case basis, but will likely not be permitted. Plan accordingly.
- There is no on-site storage available.
- There is no on-site WiFi available.
- Generators, open flames, flammable substances or hazardous materials are strictly prohibited.

- A limited amount of electrical hookups are available only to vendors who required and requested them in their Market application. No additional electricity is available.

VENDOR PARKING:

Unfortunately, we are unable to offer free vendor parking.

- Street parking is free on Sunday. All metered and 2-hour parking spaces are free; we suggest Randolph, and Albany Streets.
- There are paid lots on Albany Street. The lot across from Ink Block is \$10 - \$14 per day.
- Lots at 274 and 324 Albany Street are \$2.50 per half hour.

TAXES AND REGULATIONS:

Any vendor selling goods in Massachusetts is required to have a Tax ID number.

- This is required for both in-state and out-of-state vendors.
- If you do not have a Tax ID, you can one online via the [MA Department of Revenue](#). It is free to fill out.
- It is the vendor's responsibility to ensure they and their employees are at all times in compliance with any federal, state and local regulations, tax laws, and health protocols.

TERMS AND CONDITIONS:

Upon submitting an application, vendors agree to indemnify and hold harmless **SOWA NORTH LLC, SOWASOUTH LLC, GTI PROPERTIES INC**, and their officers, agents and employees from and against all liabilities, loss, injuries, damages, and claims arising out of or related in any way to Vendor's participation in the SoWa Open Market.

Market management and vendor conduct

SoWa Boston reserves the right to remove, deny, or terminate any vendor that in their sole judgment is being disruptive, rude or detrimental to the peaceful operation of the Market.

Smoking by vendors on the Market premises is strictly prohibited.

SoWa Boston reserves the right to request the removal of any products or items that they deem offensive, inappropriate, unsafe, or detracting from the quality of the Market.

SoWa Boston reserves the right to remove, deny, or terminate any vendor that misrepresents themselves or their products.

Vendors should immediately report any unsafe conditions to the Market manager. Any vendor notified of any safety issue must immediately correct the issue, otherwise SoWa Boston reserves the right to terminate their participation in the Market.

SoWa Boston reserves the right to add or amend any reasonable rules and regulations at any time during and prior to the operation of the Market.



Great Barrington Farmers' Market
Dennis Iodice, Market Manager
PO Box 488
Great Barrington, MA 01230

March 16, 2024

Dear Berkshire Cider Project,

I am pleased to announce that Berkshire Cider Works has been accepted as a vendor at the 2017 Great Barrington Farmers Market, pending all necessary special licensing and/or permits. This is our 34th season and we expect it to be our biggest and best yet. The market runs every Saturday 9am to 1pm, from May 11th, 2024 to November 9th, 2024. We are located right behind Main Street at 18 Church Street Great Barrington, MA.

Sincerely,

Dennis Iodice, Market Manager
Phone: 413.645.4685
Email: gbfmmanager@gmail.com

RESUME

Dennis Iodice



PROFILE

EXPERIENCE

Manager, Great Barrington Farmers' Market, Great Barrington, MA - May 2023 - Present

Business Manager, Berkshire Mountain Bakery, Housatonic, MA Nov. 2017 - Present

Vice President, Arkitektura In-Situ, San Francisco, CA Jan. 2015 - Oct. 2017

Executive Sales Manager, Arkitektura In-Situ, San Francisco, CA June 2013 - Jan. 2015

VOLUNTEER EXPERIENCE

Board Treasurer, Berkshire Food Co-op - 2023 - Present

Board President, BerkShares, Inc. - 2022 - Present

EDUCATION

Fashion Institute of Technology, NY, NY — Interior Design Program

SKILLS

Computer/Cloud; iOS, SaaS, QuickBooks Online, Shopify.

Interior Design; F.F.E. Specifications, Color, Space planning, Programming, Project Management

**APPLICATION BY A FARMER WINERY FOR LICENSE TO SELL AT A
FARMER'S MARKET
(CH.138, §15F)**

YEAR 20

2024



1. Licensee Information:

Name of Applicant: ABCC License Number:
 (If Existing Licensee)

Mailing Address: Business Name (d/b/a if different):
 Manager of Record: City/Town: State: Zip:
 Phone Number of Premises:

Other Phone: Email: Website:

Contact Person concerning this application (attorney if applicable):

Name: City/Town: State: Zip:
 Address: Email:
 Contact Number: Fax Number:

2. Event Information:

A. Farmer's Market licenses are only permitted at events that the Department of Agriculture has certified as Agricultural Events.
 Please attach document from Department of Agricultural Resources certifying that this is an agricultural event.

Date(s) of Event:

B. Contact person for applicant during event:

Name:
 Phone number of contact:

C. Description of the premises within the Farmer's Market:

Address of Premises for the Sale of Wine:
 City/Town: State: Zip: Phone Number of Premises:
 Describe Area to be Licensed:

**APPLICATION FOR LICENSE BY A FARMER WINERY TO SELL AT A
FARMER'S MARKET
(CH.138, §15F)**

Agenda Item 5g. Page 15 of 17

3. Existing License(s) to Manufacture, Export and Sell at Retail:

List the license(s) you hold which authorize the manufacture, exportation and retail sale of wine to consumers: (Attach a copy of each license)

| Name | License Type | License Address |
|-------------------------|---------------------|--------------------------------|
| Berkshire Cider Project | Farm Winery License | 508 State Road, North Adams MA |
| | | |
| | | |

4. Are you providing, without charge, samples of wine to prospective customers?

Yes No

Section 15F specifically requires that "all samples of wine shall be served by an agent, representative or solicitor of the licensee."

A. If yes, please provide names and addresses of all agents, representatives and solicitors:

| Name | Address | ABCC License Number |
|----------------|--|---------------------|
| Katherine Hand | ██ | (413) 645-4685 |
| | | |
| | | |
| | | |
| | | |

B. Proof of Age for Sale to Consumers:

Please identify all methods by which you will obtain proof of age before providing samples or making any sales of wine to consumers :

We will confirm proof of age by checking government issued ID and not sampling cider for nor selling cider to a minor

5. Transportation and Delivery:

Please identify in detail all persons or businesses that are licensed under M.G.L. c. 138, §22 that will be making any delivery of wine on your behalf to the Farmer's Market in Massachusetts.

All transportation will be handed by an approved staff member of Berkshire Cider Project

*If additional space is needed, please use last page.

**APPLICATION FOR LICENSE BY A FARMER WINERY TO SELL AT A
FARMER'S MARKET
(CH.138, §15F)**

6. Safety and Tax Registration:

Has the Farmer's Market registered with the Food and Drug Administration? Yes No Registration Date:

7. Disclosure of License Disciplinary Action:

Have any of the your licenses to sell alcoholic beverages ever been suspended, revoked or cancelled? Yes No

If yes, list said interest below:

| Date | License | Reason why license was Suspended, Revoked or Cancelled |
|------|---------|--|
| | | |
| | | |
| | | |

Pursuant to M.G.L. Ch. 62C, Sec. 49A, I certify under the penalties of perjury that, I have filed all state tax returns and paid all state taxes required under law. I further understand that each representation in this application is material to the determination of the application and state under penalty of perjury that all statements and representations therein are true.

Note: The LLA may require additional information.

Signature

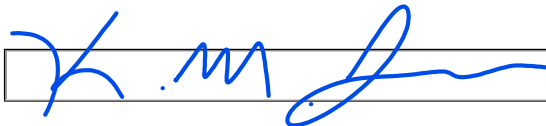

Title

Co-owner and General Manager

Date

4/1/2024

Additional Space

Please note which question you are using this space for.

A large, empty rectangular box with a thin black border, occupying most of the page below the text. It is intended for providing additional space for answers or notes.



The Commonwealth of Massachusetts
Alcoholic Beverages Control Commission
95 Fourth Street, Suite 3, Chelsea, MA 02150-2358
www.mass.gov/abcc

APPLICATION FOR MULTIPLE AMENDMENTS

Please select all of the amendments you are applying for:

CHANGE OF CATEGORY

\$200 fee via ABCC website and Payment Receipt
Monetary Transmittal Form
DOR Certificate of Good Standing
DUA Certificate of Compliance
Change of Category Application
Vote of the Entity Board
Advertisement*
Abutter's Notification*

CHANGE OF LICENSE TYPE

\$200 fee via ABCC website and Payment Receipt
Monetary Transmittal Form
Change of License Type Application
Vote of the Entity Board
Advertisement*

CHANGE OF CORPORATE STRUCTURE

\$200 fee via ABCC website and Payment Receipt
Monetary Transmittal Form
DOR Certificate of Good Standing
DUA Certificate of Compliance
Change of Corporate Structure Application
Vote of the Entity Board
Business Structure Documents
If Sole Proprietor, Business Certificate
If partnership, Partnership Agreement
If corporation or LLC, Articles of Organization from the Secretary of the Commonwealth

CHANGE OF CLASSIFICATION

\$200 fee via ABCC website and Payment Receipt
Monetary Transmittal Form
DOR Certificate of Good Standing
DUA Certificate of Compliance
Change of Classification Application
Vote of the Entity Board
Abutter's Notification*
Advertisement*

**If abutter notification and advertisement are required for transaction, please see the local licensing authority.*



The Commonwealth of Massachusetts
Alcoholic Beverages Control Commission
95 Fourth Street, Suite 3, Chelsea, MA 02150-2358
www.mass.gov/abcc

APPLICATION FOR MULTIPLE AMENDMENTS

Please select all of the amendments you are applying for(continued):

CHANGE OF OFFICERS/DIRECTORS/LLC MANAGERS

\$200 fee via [ABCC website](#) and Payment Receipt

Monetary Transmittal Form

DOR Certificate of Good Standing

DUA Certificate of Compliance

Change of Officers/Directors Application

Vote of the Entity Board

CORI Authorization Complete one for the proposed manager of record. This form must be *notarized with a stamp or raised seal.*

Business Structure Documents

If Sole Proprietor, Business Certificate

If partnership, Partnership Agreement

If corporation or LLC, Articles of Organization from the Secretary of the Commonwealth

CHANGE OF OWNERSHIP INTEREST (e.g. LLC Members, LLP Partners, Trustees etc.)

\$200 fee via [ABCC website](#) and Payment Receipt

Monetary Transmittal Form

DOR Certificate of Good Standing

DUA Certificate of Compliance

Change of Officers/Directors Application

Financial Statement

Vote of the Entity Board

CORI Authorization Complete one for the proposed manager of record. This form must be *notarized with a stamp or raised seal.*

Business Structure Documents

If Sole Proprietor, Business Certificate

If partnership, Partnership Agreement

If corporation or LLC, Articles of Organization from the Secretary of the Commonwealth

Purchase and Sale Agreement

Supporting Financial Records

Advertisement*

CHANGE OF STOCK INTEREST (e.g. New Stockholders or Transfer or Issuance of Stock)

\$200 fee via [ABCC website](#) and Payment Receipt

Monetary Transmittal Form

DOR Certificate of Good Standing ✓

DUA Certificate of Compliance ✓

Change of Officers/Directors Application ✓

Financial Statement

Vote of the Entity Board ✓

CORI Authorization Complete one for the proposed manager of record. This form must be *notarized with a stamp or raised seal.* ✓

Business Structure Documents

If Sole Proprietor, Business Certificate

If partnership, Partnership Agreement

If corporation or LLC, Articles of Organization from the Secretary of the Commonwealth ✓

Purchase and Sale Agreement

Supporting Financial Records

Advertisement*

*If abutter notification and advertisement are required for transaction, please see the local licensing authority.



The Commonwealth of Massachusetts
Alcoholic Beverages Control Commission
95 Fourth Street, Suite 3, Chelsea, MA 02150-2358
www.mass.gov/abcc

APPLICATION FOR MULTIPLE AMENDMENTS

Please select all of the amendments you are applying for(continued):

CHANGE OF CORPORATE NAME OR DBA

\$200 fee via ABCC website and Payment Receipt (Corporate Name Only)

Monetary Transmittal Form

DOR Certificate of Good Standing (Corporate Name Only)

DUA Certificate of Compliance (Corporate Name Only)

Change of Corporate Name/DBA Application

Vote of the Entity Board

Business Structure Documents

If Sole Proprietor, Business Certificate

If partnership, Partnership Agreement

If corporation or LLC, Articles of Organization from the Secretary of the Commonwealth

CHANGE OF PLEDGE OF LICENSE, STOCK OR INVENTORY

\$200 fee via ABCC website and Payment Receipt

Monetary Transmittal Form

DOR Certificate of Good Standing

DUA Certificate of Compliance

Change of Pledge of License, Stock or Inventory Application

Vote of the Entity Board

Pledge documentation

Promissory note

CHANGE OF MANAGER

\$200 fee via ABCC website and Payment Receipt

Monetary Transmittal Form

Change of Manager Application

Vote of the Entity Board

CORI Authorization Complete one for the proposed manager of record. This form must be *notarized with a stamp or raised seal.*

Proof of Citizenship. Passport, birth certificate, voter registration, or naturalization papers will be accepted.



The Commonwealth of Massachusetts
Alcoholic Beverages Control Commission
95 Fourth Street, Suite 3, Chelsea, MA 02150-2358
www.mass.gov/abcc

APPLICATION FOR MULTIPLE AMENDMENTS

Please select all of the amendments you are applying for(continued):

CHANGE OF LOCATION

\$200 fee via [ABCC website](#) and Payment Receipt
Monetary Transmittal Form
Alteration of Premises/Change of Location Application
Vote of the Entity Board
Supporting financial records
Legal Right to Occupy
Floor Plan
Abutter's Notification*
Advertisement*

ALTERATION OF PREMISES

\$200 fee via [ABCC website](#) and Payment Receipt
Monetary Transmittal Form
Alteration of Premises/Change of Location Application
Vote of the Entity Board
Supporting financial records
Legal Right to Occupy
Floor Plan
Abutter's Notification*
Advertisement*

MANAGEMENT AGREEMENT

\$200 fee via [ABCC website](#) and Payment Receipt
Monetary Transmittal Form
Management Agreement Application
Management Agreement
Vote of the Entity Board
CORI Forms for all listed in Section 8A and attachments

IMPORTANT NOTE: A management agreement is where a licensee authorizes a third party to control the daily operations of the license premises, while retaining ultimate control over the license, through a written contract. *This does not pertain to a liquor license manager that is employed directly by the entity.*



The Commonwealth of Massachusetts
Alcoholic Beverages Control Commission
95 Fourth Street, Suite 3, Chelsea, MA 02150-2358
www.mass.gov/abcc

APPLICATION FOR MULTIPLE AMENDMENTS

Please select all of the amendments you are applying for(continued):

Non-Profit Club's ONLY

e.g. Veterans Club

Non-Profit Club CHANGE OF OFFICERS/DIRECTORS

DOR Certificate of Good Standing
DUA Certificate of Compliance
Change of Officers/Directors Application
Vote of the club signed by an approved officer
Business Structure Documents-Articles of Organization from the Secretary of the Commonwealth
Monetary Transmittal Form
\$200 fee via [ABCC website](#) and Payment Receipt

Non-Profit Club CHANGE OF MANAGER

\$200 fee via [ABCC website](#) and Payment Receipt
Monetary Transmittal Form
Change of Manager Application
Vote of the club signed by an approved officer
CORI Authorization Complete one for the proposed manager of record. This form must be *notarized with a stamp or raised seal*.
Updated Officers and Directors*
*Please ensure to update your officers and directors *simultaneously* or PRIOR to applying for a change of manager. It will be returned with no action taken if the officers and directors do not match ABCC records.
Proof of Citizenship. Passport, birth certificate, voter registration, or naturalization papers will be accepted.



The Commonwealth of Massachusetts
Alcoholic Beverages Control Commission
95 Fourth Street, Suite 3, Chelsea, MA 02150-2358
www.mass.gov/abcc

RETAIL ALCOHOLIC BEVERAGES LICENSE APPLICATION
MONETARY TRANSMITTAL FORM

APPLICATION FOR MULTIPLE AMENDMENTS

APPLICATION SHOULD BE COMPLETED ON-LINE, PRINTED, SIGNED, AND SUBMITTED TO THE LOCAL LICENSING AUTHORITY.

ECRT CODE: RETA

Please make \$200.00 payment here: ABCC PAYMENT WEBSITE

PAYMENT MUST DENOTE THE NAME OF THE LICENSEE CORPORATION, LLC, PARTNERSHIP, OR INDIVIDUAL AND INCLUDE THE PAYMENT RECEIPT

ABCC LICENSE NUMBER (IF AN EXISTING LICENSEE, CAN BE OBTAINED FROM THE CITY)

ENTITY/ LICENSEE NAME

ADDRESS

CITY/TOWN

STATE

ZIP CODE

For the following transactions (Check all that apply):

- New License
- Change of Location
- Change of Class (i.e. Annual / Seasonal)
- Change Corporate Structure (i.e. Corp / LLC)
- Transfer of License
- Alteration of Licensed Premises
- Change of License Type (i.e. club / restaurant)
- Pledge of Collateral (i.e. License/Stock)
- Change of Manager
- Change Corporate Name
- Change of Category (i.e. All Alcohol/Wine, Malt)
- Management/Operating Agreement
- Change of Officers/
Directors/LLC Managers
- Change of Ownership Interest
(LLC Members/ LLP Partners,
Trustees)
- Issuance/Transfer of Stock/New Stockholder
- Change of Hours
- Other
- Change of DBA

THE LOCAL LICENSING AUTHORITY MUST SUBMIT THIS APPLICATION ONCE APPROVED VIA THE ePLACE PORTAL

Alcoholic Beverages Control Commission
95 Fourth Street, Suite 3
Chelsea, MA 02150-2358



The Commonwealth of Massachusetts
 Alcoholic Beverages Control Commission
 95 Fourth Street, Suite 3, Chelsea, MA 02150-2358
 www.mass.gov/abcc

APPLICATION FOR MULTIPLE AMENDMENTS

1. BUSINESS ENTITY INFORMATION

| | | |
|-----------------------------------|--------------|---------------------|
| Entity Name Table & Vine, Inc. | Municipality | ABCC License Number |
|-----------------------------------|--------------|---------------------|

Please provide a narrative overview of the transaction(s) being applied for. On-premises applicants should also provide a description of the intended theme or concept of the business operation. Attach additional pages, if necessary.

*Please see next page for overview

APPLICATION CONTACT

The application contact is the person who should be contacted with any questions regarding this application.

| Name | Title | Email | Phone |
|-----------------|---------------|------------|------------|
| Michael S. Gold | VP, Secretary | [REDACTED] | [REDACTED] |

2. AMENDMENT-Change of License Classification

| | | |
|--|--------------------------------|------------|
| <input type="checkbox"/> Change of License Category All Alcohol, Wine and Malt, Wine Malt and Cordials | Last-Approved License Category | [Dropdown] |
| | Requested New License Category | [Dropdown] |
| <input type="checkbox"/> Change of License Class Seasonal or Annual | Last-Approved License Class | [Dropdown] |
| | Requested New License Class | [Dropdown] |
| <input type="checkbox"/> Change of License Type* i.e. Restaurant to Club *Certain License Types CANNOT change once issued* | Last-Approved License Type | [Dropdown] |
| | Requested New License Type | [Dropdown] |

3. AMENDMENT-Change of Business Entity Information

| | | |
|--|-----------------------------------|------------|
| <input type="checkbox"/> Change of Corporate Name | Last-Approved Corporate Name: | [Text Box] |
| | Requested New Corporate Name: | [Text Box] |
| <input type="checkbox"/> Change of DBA | Last-Approved DBA: | [Text Box] |
| | Requested New DBA: | [Text Box] |
| <input type="checkbox"/> Change of Corporate Structure LLC, Corporation, Sole Proprietor, etc | Last-Approved Corporate Structure | [Dropdown] |
| | Requested New Corporate Structure | [Dropdown] |

4. AMENDMENT-Pledge Information

| | | |
|---|-----------------------------------|------------|
| <input type="checkbox"/> Pledge of License | To whom is the pledge being made: | [Text Box] |
| <input type="checkbox"/> Pledge of Inventory | | |
| <input type="checkbox"/> Pledge of Stock | | |

Summary of Transactions-2023

Updated 1/15/2024

Background

Table & Vine, Inc. (T&V) holds nine (9) §15 Alcohol Beverages Retail Licenses as well as a §18 Wholesale License.

T&V is a wholly-owned subsidiary of Big Y Foods, Inc., a Massachusetts Corporation (T&V is effectively the “liquor division” of Big Y). Big Y is owned and operated by the D’Amour family. It was founded by two brothers, Paul and Gerry D’Amour; currently second and third generation D’Amours manage the company. All shares of stock are owned by D’Amour family members or trusts for the benefit of D’Amour family members. Big Y operates 91 locations throughout Massachusetts and Connecticut including 73 supermarkets, Table & Vine Fine Wines and Liquors and 17 Big Y Express gas and convenience locations with over 10,000 employees.

At the end of 2020, Donald D’Amour and Charles D’Amour (at that time the only 2 shareholders of Big Y) transferred Non-Voting shares of Big Y by gift in accordance with succession and tax planning to trusts they had established for the benefit of their adult children.

Charles now is transferring additional Non-Voting shares of Big Y by (i) gift and (ii) sale to the same Trust he gifted shares in 2020.

Donald now is transferring additional Non-Voting shares of Big Y by sale to the same Trust that he gifted shares in 2020.

Donald is also transferring all of his Voting shares of Big Y by gift to his son, Michael D’Amour.

Additionally, Charles and Michael have transferred all of their respective Voting Shares of Big Y to a Voting Trust of which they will be the Trustees and beneficiaries.

Finally, Charles D’Amour and Claire D’Amour Daley have resigned as Directors and Officers of T&V; they have been replaced by Christian D’Amour (Charles’s son) and Nicole D’Amour Schneider (Donald’s daughter).

Please note, on 12/27/23, Theresa Jasmin Niemczura resigned as Trustee of the Donald D’Amour Gifting Trust U/A 12/29/2020, on that same date Todd Schneider accepted appointment as trustee of the Donald D’Amour Gifting Trust U/A 12/29/2020

Shareholders:

- Charles D’Amour
- Charles D’Amour 2020 Family Irrevocable Trust:
 - Trustee: Fiduciary Trust Company of New England (LLC Agreement attached);
 - Beneficiaries: Emily D’Amour, Colin D’Amour, Margaret D’Amour and Christian D’Amour.
- Donald D’Amour
- Donald D’Amour Gifting Trust U/A 12/29/2020:
 - Trustees: Michele D’Amour, Caroline Demirs Calio and Todd Schneider;
 - Beneficiaries: Michael D’Amour, Nicole D’Amour-Schneider and Matheiu D’Amour.
- Big Y Foods Voting Trust U/A 9/1/2023
 - Trustees: Michael D’Amour, Charles D’Amour
 - Beneficiaries: Michael D’Amour, Charles D’Amour

Summary of Table & Vine Inc
 Change of Beneficial Ownership
 January 15, 2024
 Page 2 of 2

Table & Vine, Inc.
 Ownership Chart
 Class B Non Voting Shares

Prior to 2023 Transactions

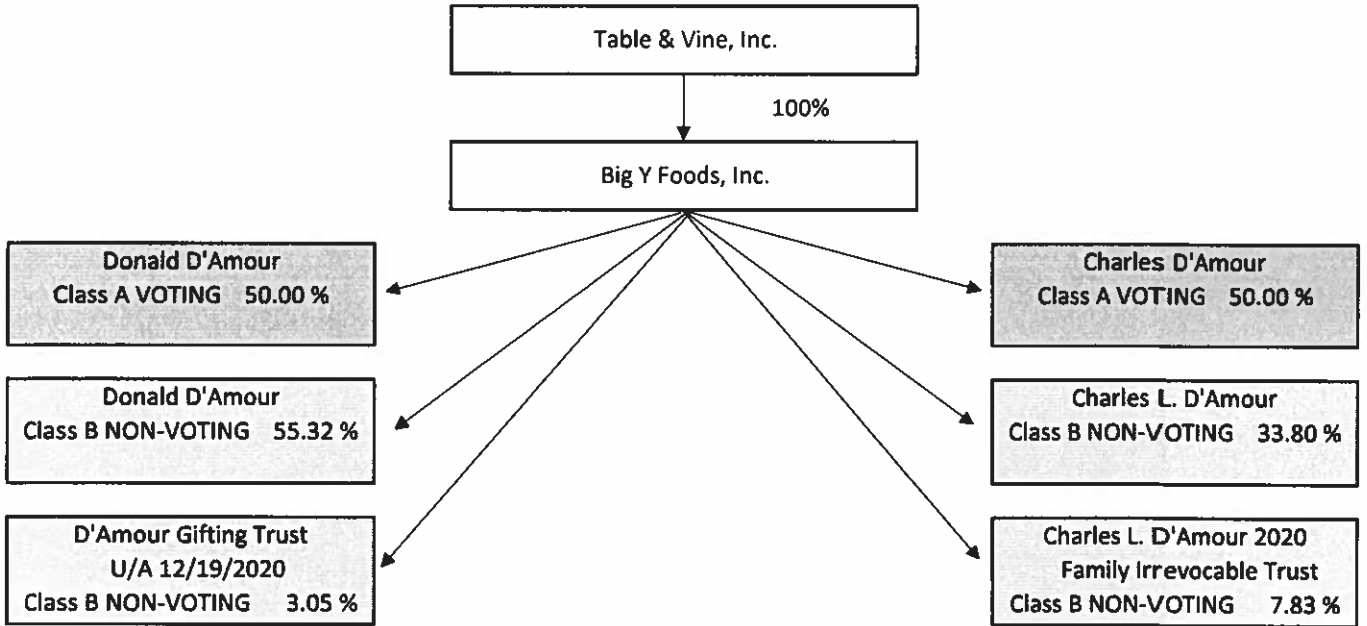

After 2023 Transactions

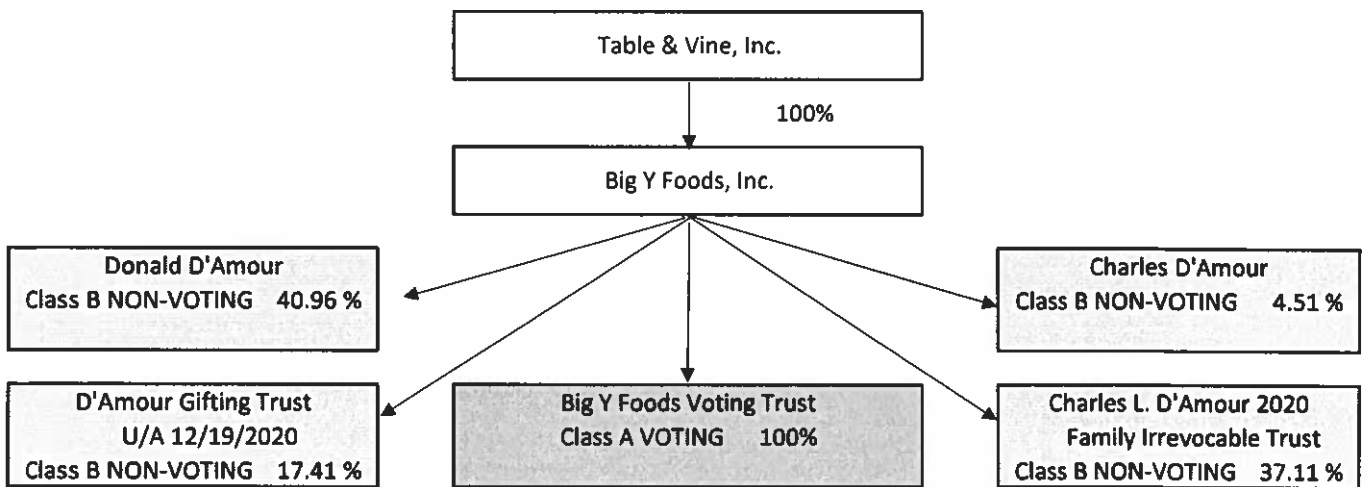

5. AMENDMENT-Change of Manager

Change of License Manager

A. MANAGER INFORMATION

The individual that has been appointed to manage and control the licensed business and premises.

Proposed Manager Name Date of Birth SSN

Residential Address

Email Phone

Please indicate how many hours per week you intend to be on the licensed premises Last-Approved License Manager

B. CITIZENSHIP/BACKGROUND INFORMATION

Are you a U.S. Citizen? Yes No *Manager must be a U.S. Citizen

If yes, attach one of the following as proof of citizenship US Passport, Voter's Certificate, Birth Certificate or Naturalization Papers.

Have you ever been convicted of a state, federal, or military crime? Yes No

If yes, fill out the table below and attach an affidavit providing the details of any and all convictions. Attach additional pages, if necessary, utilizing the format below.

| Date | Municipality | Charge | Disposition |
|------|--------------|--------|-------------|
| | | | |
| | | | |
| | | | |

C. EMPLOYMENT INFORMATION

Please provide your employment history. Attach additional pages, if necessary, utilizing the format below.

| Start Date | End Date | Position | Employer | Supervisor Name |
|------------|----------|----------|----------|-----------------|
| | | | | |
| | | | | |
| | | | | |

D. PRIOR DISCIPLINARY ACTION

Have you held a beneficial or financial interest in, or been the manager of, a license to sell alcoholic beverages that was subject to disciplinary action? Yes No If yes, please fill out the table. Attach additional pages, if necessary,utilizing the format below.

| Date of Action | Name of License | State | City | Reason for suspension, revocation or cancellation |
|----------------|-----------------|-------|------|---|
| | | | | |
| | | | | |
| | | | | |

I hereby swear under the pains and penalties of perjury that the information I have provided in this application is true and accurate.

Manager's Signature Date

6. AMENDMENT-Change of Officers, Stock or Ownership Interest

Change of Officers/Directors **Change of Ownership Interest (LLC Managers/LLP Partners, Trustees)** **Change of Stock (E.g. New Stockholder/ Transfer or Issuance of Stock)**

List all individuals or entities that will have a direct or indirect, beneficial or financial interest in this license (E.g. Stockholders, Officers, Directors, LLC Managers, LLP Partners, Trustees etc.). Attach additional page(s) provided, if necessary, utilizing Addendum A.

- The individuals and titles listed in this section must be identical to those filed with the Massachusetts Secretary of State.
- The individuals identified in this section, as well as the proposed Manager of Record, must complete a CORI Release Form.
- Please note the following statutory requirements for Directors and LLC Managers:
On Premises (E.g. Restaurant/ Club/Hotel) Directors or LLC Managers - At least 50% must be US citizens;
Off Premises (Liquor Store) Directors or LLC Managers - All must be US citizens and a majority must be Massachusetts residents.
- If you are a Multi-Tiered Organization, please attach a flow chart identifying each corporate interest and the individual owners of each entity as well as the Articles of Organization for each corporate entity. Every individual must be identified in Addendum A.

| Name of Principal | Residential Address | SSN | DOB | Title and or Position | Percentage of Ownership | Director/ LLC Manager | US Citizen | MA Resident |
|------------------------------|---------------------|------------|------------|--------------------------------|-------------------------|---|---|---|
| Michael P. D'Amour | [REDACTED] | [REDACTED] | [REDACTED] | President, Director, Treasurer | 0 | <input checked="" type="radio"/> Yes <input type="radio"/> No | <input checked="" type="radio"/> Yes <input type="radio"/> No | <input type="radio"/> Yes <input checked="" type="radio"/> No |
| Michael S. Gold | [REDACTED] | [REDACTED] | [REDACTED] | VP, Secretary | 0 | <input type="radio"/> Yes <input checked="" type="radio"/> No | <input checked="" type="radio"/> Yes <input type="radio"/> No | <input type="radio"/> Yes <input checked="" type="radio"/> No |
| Thereasa A. Jasmin Niemczura | [REDACTED] | [REDACTED] | [REDACTED] | VP, Asst Secretary | 0 | <input type="radio"/> Yes <input checked="" type="radio"/> No | <input checked="" type="radio"/> Yes <input type="radio"/> No | <input checked="" type="radio"/> Yes <input type="radio"/> No |
| Christian D'Amour | [REDACTED] | [REDACTED] | [REDACTED] | Director | 0 | <input checked="" type="radio"/> Yes <input type="radio"/> No | <input checked="" type="radio"/> Yes <input type="radio"/> No | <input checked="" type="radio"/> Yes <input type="radio"/> No |
| Nicole Schneider | [REDACTED] | [REDACTED] | [REDACTED] | Director | 0 | <input checked="" type="radio"/> Yes <input type="radio"/> No | <input checked="" type="radio"/> Yes <input type="radio"/> No | <input checked="" type="radio"/> Yes <input type="radio"/> No |
| Big Y Foods, Inc. | [REDACTED] | [REDACTED] | [REDACTED] | Corporation | 100 | <input type="radio"/> Yes <input type="radio"/> No | <input type="radio"/> Yes <input type="radio"/> No | <input type="radio"/> Yes <input type="radio"/> No |

Additional pages attached? Yes No

CRIMINAL HISTORY

Has any individual listed in question 6, and applicable attachments, ever been convicted of a State, Federal or Military Crime? If yes, attach an affidavit providing the details of any and all convictions.

Yes No

MANAGEMENT AGREEMENT

Are you requesting approval to utilize a management company through a management agreement? Please provide a copy of the management agreement.

Yes No

6. AMENDMENT-Change of Officers, Stock or Ownership Interest

6B. CURRENT OFFICERS, STOCK OR OWNERSHIP INTEREST

List the individuals and entities of the current ownership. Attach additional pages if necessary utilizing the format below.

| Name of Principal | Title/Position | Percentage of Ownership |
|------------------------------|---|-------------------------|
| Charles L. D'Amour | President, CEO, Treasurer, Director | 0 |
| Michael P. D'Amour | Executive Vice President, COO, Director | 0 |
| Claire M. D'Amour Daley | Secretary, Director | 0 |
| Michael S. Gold | VP, Asst Secretary | 0 |
| Thereasa A. Jasmin Niemczura | VP, CFO | 0 |
| Big Y Foods, Inc. | Corporation | 100 |

6A. INTEREST IN AN ALCOHOLIC BEVERAGES LICENSE

Does any individual or entity identified in question 6, and applicable attachments, have any direct or indirect, beneficial or financial interest in any other license to sell alcoholic beverages? Yes No If yes, list in table below. Attach additional pages, if necessary, utilizing the table format below.

| Name | License Type | License Name | Municipality |
|-------------------|--------------------|-------------------|----------------------|
| Big Y Foods, Inc. | \$15 Package Store | Table & Vine, Inc | Northampton, MA |
| Big Y Foods, inc. | \$15 Package Store | Table & Vine, Inc | Great Barrington, MA |
| Big Y Foods, inc. | \$15 Package Store | Table & Vine, Inc | Holden, MA |

6B. PREVIOUSLY HELD INTEREST IN AN ALCOHOLIC BEVERAGES LICENSE

Has any individual or entity identified in question 6, and applicable attachments, ever held a direct or indirect, beneficial or financial interest in a license to sell alcoholic beverages, which is not presently held? Yes No If yes, list in table below. Attach additional pages, if necessary, utilizing the table format below.

| Name | License Type | License Name | Municipality |
|-------------------|--------------------|--------------------|---------------|
| Big Y Foods, Inc. | \$15 Package Store | Table & Vine, Inc. | Southwick, MA |
| Big Y Foods, Inc. | \$15 Package Store | Table & Vine, Inc | Quincy, MA |
| | | | |

6C. DISCLOSURE OF LICENSE DISCIPLINARY ACTION

Have any of the disclosed licenses listed in question 6A or 6B ever been suspended, revoked or cancelled? Yes No If yes, list in table below. Attach additional pages, if necessary, utilizing the table format below.

| Date of Action | Name of License | City | Reason for suspension, revocation or cancellation |
|----------------|-----------------|------|---|
| | | | |
| | | | |
| | | | |

6. Change of Officers, Stock or Ownership Interest (Continued...)

List all proposed individuals or entities that will have a direct or indirect, beneficial or financial interest in this license (E.g. Stockholders, Officers, Directors, LLC Managers, LLP Partners, Trustees etc.).

Entity Name

Big Y Foods, Inc

Percentage of Ownership in Entity being Licensed
(Write "NA" if this is the entity being licensed)

40.96% (of Big Y Foods)

Name of Principal

Donald D'Amour

Residential Address

[REDACTED]

SSN

[REDACTED]

DOB

[REDACTED]

Title and or Position

Owner

Percentage of Ownership

40.96% (of Big Y Foods)

Director/ LLC Manager

Yes No

US Citizen

Yes No

MA Resident

Yes No

Name of Principal

Residential Address

SSN

DOB

Title and or Position

Percentage of Ownership

Director/ LLC Manager

Yes No

US Citizen

Yes No

MA Resident

Yes No

Name of Principal

Residential Address

SSN

DOB

Title and or Position

Percentage of Ownership

Director/ LLC Manager

Yes No

US Citizen

Yes No

MA Resident

Yes No

Name of Principal

Residential Address

SSN

DOB

Title and or Position

Percentage of Ownership

Director/ LLC Manager

Yes No

US Citizen

Yes No

MA Resident

Yes No

Name of Principal

Residential Address

SSN

DOB

Title and or Position

Percentage of Ownership

Director/ LLC Manager

Yes No

US Citizen

Yes No

MA Resident

Yes No

Name of Principal

Residential Address

SSN

DOB

Title and or Position

Percentage of Ownership

Director/ LLC Manager

Yes No

US Citizen

Yes No

MA Resident

Yes No

Name of Principal

Residential Address

SSN

DOB

Title and or Position

Percentage of Ownership

Director/ LLC Manager

Yes No

US Citizen

Yes No

MA Resident

Yes No

CRIMINAL HISTORY

Has any individual identified above ever been convicted of a State, Federal or Military Crime?
If yes, attach an affidavit providing the details of any and all convictions.

Yes No

6. Change of Officers, Stock or Ownership Interest (Continued...)

List all proposed individuals or entities that will have a direct or indirect, beneficial or financial interest in this license (E.g. Stockholders, Officers, Directors, LLC Managers, LLP Partners, Trustees etc.).

Entity Name

Big Y Foods ,Inc

Percentage of Ownership in Entity being Licensed (Write "NA" if this is the entity being licensed)

17.41% (of Big Y Foods

Name of Principal

Donald D'Amour Gifting Trust

Residential Address

[Redacted]

SSN

[Redacted]

DOB

[Redacted]

Title and or Position

Owner/ Trust

Percentage of Ownership

[Redacted]

Director/ LLC Manager

Yes No

US Citizen

Yes No

MA Resident

Yes No

Name of Principal

Todd Schneider

Residential Address

[Redacted]

SSN

[Redacted]

DOB

[Redacted]

Title and or Position

Trustee

Percentage of Ownership

[Redacted]

Director/ LLC Manager

Yes No

US Citizen

Yes No

MA Resident

Yes No

Name of Principal

Michele D'Amour

Residential Address

[Redacted]

SSN

[Redacted]

DOB

[Redacted]

Title and or Position

Trustee

Percentage of Ownership

[Redacted]

Director/ LLC Manager

Yes No

US Citizen

Yes No

MA Resident

Yes No

Name of Principal

Caroline Demirs-Calio

Residential Address

[Redacted]

SSN

[Redacted]

DOB

[Redacted]

Title and or Position

Trustee

Percentage of Ownership

[Redacted]

Director/ LLC Manager

Yes No

US Citizen

Yes No

MA Resident

Yes No

Name of Principal

Michael D'Amour

Residential Address

[Redacted]

SSN

[Redacted]

DOB

[Redacted]

Title and or Position

Beneficiary

Percentage of Ownership

[Redacted]

Director/ LLC Manager

Yes No

US Citizen

Yes No

MA Resident

Yes No

Name of Principal

Nicole Schneider

Residential Address

[Redacted]

SSN

[Redacted]

DOB

[Redacted]

Title and or Position

Beneficiary

Percentage of Ownership

[Redacted]

Director/ LLC Manager

Yes No

US Citizen

Yes No

MA Resident

Yes No

Name of Principal

Matheiu D'Amour

Residential Address

[Redacted]

SSN

[Redacted]

DOB

[Redacted]

Title and or Position

Beneficiary

Percentage of Ownership

[Redacted]

Director/ LLC Manager

Yes No

US Citizen

Yes No

MA Resident

Yes No

CRIMINAL HISTORY

Has any individual identified above ever been convicted of a State, Federal or Military Crime? If yes, attach an affidavit providing the details of any and all convictions.

Yes No

6. Change of Officers, Stock or Ownership Interest (Continued...)

List all proposed individuals or entities that will have a direct or indirect, beneficial or financial interest in this license (E.g. Stockholders, Officers, Directors, LLC Managers, LLP Partners, Trustees etc.).

Entity Name

Big Y Foods ,Inc

Percentage of Ownership in Entity being Licensed
(Write "NA" if this is the entity being licensed)

4.51% (of Big Y Foods)

Name of Principal

Charles D'Amour

Residential Address

[Redacted]

SSN

[Redacted]

DOB

[Redacted]

Title and or Position

Owner

Percentage of Ownership

Director/ LLC Manager

Yes No

US Citizen

Yes No

MA Resident

Yes No

Name of Principal

Residential Address

SSN

DOB

Title and or Position

Percentage of Ownership

Director/ LLC Manager

Yes No

US Citizen

Yes No

MA Resident

Yes No

Name of Principal

Residential Address

SSN

DOB

Title and or Position

Percentage of Ownership

Director/ LLC Manager

Yes No

US Citizen

Yes No

MA Resident

Yes No

Name of Principal

Residential Address

SSN

DOB

Title and or Position

Percentage of Ownership

Director/ LLC Manager

Yes No

US Citizen

Yes No

MA Resident

Yes No

Name of Principal

Residential Address

SSN

DOB

Title and or Position

Percentage of Ownership

Director/ LLC Manager

Yes No

US Citizen

Yes No

MA Resident

Yes No

Name of Principal

Residential Address

SSN

DOB

Title and or Position

Percentage of Ownership

Director/ LLC Manager

Yes No

US Citizen

Yes No

MA Resident

Yes No

Name of Principal

Residential Address

SSN

DOB

Title and or Position

Percentage of Ownership

Director/ LLC Manager

Yes No

US Citizen

Yes No

MA Resident

Yes No

CRIMINAL HISTORY

Has any individual identified above ever been convicted of a State, Federal or Military Crime?
If yes, attach an affidavit providing the details of any and all convictions.

Yes No

6. Change of Officers, Stock or Ownership Interest (Continued...)

List all proposed individuals or entities that will have a direct or indirect, beneficial or financial interest in this license (E.g. Stockholders, Officers, Directors, LLC Managers, LLP Partners, Trustees etc.).

Entity Name

Big Y Foods ,Inc

Percentage of Ownership in Entity being Licensed (Write "NA" if this is the entity being licensed)

37.11% (of Big Y Foods

| | | | |
|-----------------------------------|---------------------|-----|-----|
| Name of Principal | Residential Address | SSN | DOB |
| Charles D'Amour 2020 Family Trust | | | |

| | | | | |
|-----------------------|-------------------------|---|--|--|
| Title and or Position | Percentage of Ownership | Director/ LLC Manager | US Citizen | MA Resident |
| Owner/ Trust | | <input type="radio"/> Yes <input checked="" type="radio"/> No | <input type="radio"/> Yes <input type="radio"/> No | <input type="radio"/> Yes <input type="radio"/> No |

| | | | |
|--------------------------------|---------------------|-----|-----|
| Name of Principal | Residential Address | SSN | DOB |
| Fiduciary Trust of New England | | | |

| | | | | |
|-----------------------|-------------------------|---|---|---|
| Title and or Position | Percentage of Ownership | Director/ LLC Manager | US Citizen | MA Resident |
| Trustee | | <input type="radio"/> Yes <input checked="" type="radio"/> No | <input checked="" type="radio"/> Yes <input type="radio"/> No | <input checked="" type="radio"/> Yes <input type="radio"/> No |

| | | | |
|-------------------|---------------------|-----|-----|
| Name of Principal | Residential Address | SSN | DOB |
| Christian D'Amour | | | |

| | | | | |
|-----------------------|-------------------------|---|---|---|
| Title and or Position | Percentage of Ownership | Director/ LLC Manager | US Citizen | MA Resident |
| Beneficiary | | <input checked="" type="radio"/> Yes <input type="radio"/> No | <input checked="" type="radio"/> Yes <input type="radio"/> No | <input checked="" type="radio"/> Yes <input type="radio"/> No |

| | | | |
|-------------------|---------------------|-----|-----|
| Name of Principal | Residential Address | SSN | DOB |
| Emily D'Amour | | | |

| | | | | |
|-----------------------|-------------------------|---|---|---|
| Title and or Position | Percentage of Ownership | Director/ LLC Manager | US Citizen | MA Resident |
| Beneficiary | | <input type="radio"/> Yes <input checked="" type="radio"/> No | <input checked="" type="radio"/> Yes <input type="radio"/> No | <input checked="" type="radio"/> Yes <input type="radio"/> No |

| | | | |
|-------------------|---------------------|-----|-----|
| Name of Principal | Residential Address | SSN | DOB |
| Colin D'Amour | | | |

| | | | | |
|-----------------------|-------------------------|---|---|---|
| Title and or Position | Percentage of Ownership | Director/ LLC Manager | US Citizen | MA Resident |
| Beneficiary | | <input type="radio"/> Yes <input checked="" type="radio"/> No | <input checked="" type="radio"/> Yes <input type="radio"/> No | <input type="radio"/> Yes <input checked="" type="radio"/> No |

| | | | |
|-------------------|---------------------|-----|-----|
| Name of Principal | Residential Address | SSN | DOB |
| Margaret D'Amour | | | |

| | | | | |
|-----------------------|-------------------------|---|---|---|
| Title and or Position | Percentage of Ownership | Director/ LLC Manager | US Citizen | MA Resident |
| Beneficiary | | <input type="radio"/> Yes <input checked="" type="radio"/> No | <input checked="" type="radio"/> Yes <input type="radio"/> No | <input checked="" type="radio"/> Yes <input type="radio"/> No |

| | | | |
|-------------------|---------------------|-----|-----|
| Name of Principal | Residential Address | SSN | DOB |
| | | | |

| | | | | |
|-----------------------|-------------------------|--|--|--|
| Title and or Position | Percentage of Ownership | Director/ LLC Manager | US Citizen | MA Resident |
| | | <input type="radio"/> Yes <input type="radio"/> No | <input type="radio"/> Yes <input type="radio"/> No | <input type="radio"/> Yes <input type="radio"/> No |

CRIMINAL HISTORY

Has any individual identified above ever been convicted of a State, Federal or Military Crime? If yes, attach an affidavit providing the details of any and all convictions.

Yes No

ADDENDUM A

6. Change of Officers, Stock or Ownership Interest (Continued...)

List all proposed individuals or entities that will have a direct or indirect, beneficial or financial interest in this license (E.g. Stockholders, Officers, Directors, LLC Managers, LLP Partners, Trustees etc.).

| | |
|--|---|
| Entity Name | Percentage of Ownership in Entity being Licensed (Write "NA" if this is the entity being licensed) |
| <input type="text" value="Big Y Foods, Inc."/> | <input type="text" value="100% of Class A Shares"/> |

| | | | |
|---|--|--|--|
| Name of Principal | Residential Address | SSN | DOB |
| <input type="text" value="Big Y Foods Voting Trust"/> | <input type="text" value="2145 Roosevelt Ave, Springfield, MA 01104"/> | <input type="text"/> | <input type="text"/> |
| Title and or Position | Percentage of Ownership | Director/ LLC Manager | US Citizen |
| <input type="text" value="Trust"/> | <input type="text" value="100% of Class A Shares"/> | <input type="radio"/> Yes <input type="radio"/> No | <input type="radio"/> Yes <input type="radio"/> No |
| | | | MA Resident |
| | | | <input type="radio"/> Yes <input type="radio"/> No |

| | | | |
|---|-------------------------|---|---|
| Name of Principal | Residential Address | SSN | DOB |
| <input type="text" value="Charles L. D'Amour"/> | <input type="text"/> | <input type="text"/> | <input type="text"/> |
| Title and or Position | Percentage of Ownership | Director/ LLC Manager | US Citizen |
| <input type="text" value="Trustee"/> | <input type="text"/> | <input checked="" type="radio"/> Yes <input type="radio"/> No | <input checked="" type="radio"/> Yes <input type="radio"/> No |
| | | | MA Resident |
| | | | <input checked="" type="radio"/> Yes <input type="radio"/> No |

| | | | |
|---|-------------------------|---|---|
| Name of Principal | Residential Address | SSN | DOB |
| <input type="text" value="Michael P. D'Amour"/> | <input type="text"/> | <input type="text"/> | <input type="text"/> |
| Title and or Position | Percentage of Ownership | Director/ LLC Manager | US Citizen |
| <input type="text" value="Trustee"/> | <input type="text"/> | <input checked="" type="radio"/> Yes <input type="radio"/> No | <input checked="" type="radio"/> Yes <input type="radio"/> No |
| | | | MA Resident |
| | | | <input type="radio"/> Yes <input checked="" type="radio"/> No |

| | | | |
|-----------------------|-------------------------|--|--|
| Name of Principal | Residential Address | SSN | DOB |
| <input type="text"/> | <input type="text"/> | <input type="text"/> | <input type="text"/> |
| Title and or Position | Percentage of Ownership | Director/ LLC Manager | US Citizen |
| <input type="text"/> | <input type="text"/> | <input type="radio"/> Yes <input type="radio"/> No | <input type="radio"/> Yes <input type="radio"/> No |
| | | | MA Resident |
| | | | <input type="radio"/> Yes <input type="radio"/> No |

| | | | |
|-----------------------|-------------------------|--|--|
| Name of Principal | Residential Address | SSN | DOB |
| <input type="text"/> | <input type="text"/> | <input type="text"/> | <input type="text"/> |
| Title and or Position | Percentage of Ownership | Director/ LLC Manager | US Citizen |
| <input type="text"/> | <input type="text"/> | <input type="radio"/> Yes <input type="radio"/> No | <input type="radio"/> Yes <input type="radio"/> No |
| | | | MA Resident |
| | | | <input type="radio"/> Yes <input type="radio"/> No |

| | | | |
|-----------------------|-------------------------|--|--|
| Name of Principal | Residential Address | SSN | DOB |
| <input type="text"/> | <input type="text"/> | <input type="text"/> | <input type="text"/> |
| Title and or Position | Percentage of Ownership | Director/ LLC Manager | US Citizen |
| <input type="text"/> | <input type="text"/> | <input type="radio"/> Yes <input type="radio"/> No | <input type="radio"/> Yes <input type="radio"/> No |
| | | | MA Resident |
| | | | <input type="radio"/> Yes <input type="radio"/> No |

| | | | |
|-----------------------|-------------------------|--|--|
| Name of Principal | Residential Address | SSN | DOB |
| <input type="text"/> | <input type="text"/> | <input type="text"/> | <input type="text"/> |
| Title and or Position | Percentage of Ownership | Director/ LLC Manager | US Citizen |
| <input type="text"/> | <input type="text"/> | <input type="radio"/> Yes <input type="radio"/> No | <input type="radio"/> Yes <input type="radio"/> No |
| | | | MA Resident |
| | | | <input type="radio"/> Yes <input type="radio"/> No |

CRIMINAL HISTORY

Has any individual identified above ever been convicted of a State, Federal or Military Crime? Yes No

If yes, attach an affidavit providing the details of any and all convictions.

6A . INTEREST IN AN ALCOHOLIC BEVERAGES LICENSE (CONT.)

TABLE & VINE, INC.

MA ALCOHOLIC BEVERAGES LICENSES

| Name | License Type | License Name | Municipality |
|------------------|---------------------|---------------------|----------------------|
| Big Y Foods, Inc | §15 Package Store | Table & Vine, Inc. | Franklin, MA |
| Big Y Foods, Inc | §15 Package Store | Table & Vine, Inc. | Greenfield, MA |
| Big Y Foods, Inc | §15 Package Store | Table & Vine, Inc. | Springfield, MA |
| Big Y Foods, Inc | §15 Package Store | Table & Vine, Inc. | Wilbraham, MA |
| Big Y Foods, Inc | §15 Package Store | Table & Vine, Inc. | West Springfield, MA |
| Big Y Foods, Inc | §15 Package Store | Table & Vine, Inc. | Norwell, MA |
| Big Y Foods, Inc | §18 Wholesaler | Table & Vine, Inc. | Springfield, MA |

7. AMENDMENT-Change of Premises Information

Alteration of Premises: (must fill out attached financial information form)

7A. ALTERATION OF PREMISES

Please summarize the details of the alterations and highlight any specific changes from the last-approved premises.

PROPOSED DESCRIPTION OF PREMISES

Please provide a complete description of the proposed premises, including the number of floors, number of rooms on each floor, any outdoor areas to be included in the licensed area, and total square footage. You must also submit a floor plan.

| | | | | | |
|---------------------|----------------------|------------------|----------------------|------------------|----------------------|
| Total Sq. Footage | <input type="text"/> | Seating Capacity | <input type="text"/> | Occupancy Number | <input type="text"/> |
| Number of Entrances | <input type="text"/> | Number of Exits | <input type="text"/> | Number of Floors | <input type="text"/> |

Change of Location: (must fill out attached financial information form)

7B. CHANGE OF LOCATION

Last-Approved Street Address

Proposed Street Address

DESCRIPTION OF PREMISES

Please provide a complete description of the premises to be licensed, including the number of floors, number of rooms on each floor, any outdoor areas to be included in the licensed area, and total square footage. You must also submit a floor plan.

| | | | | | |
|---------------------|----------------------|------------------|----------------------|------------------|----------------------|
| Total Sq. Footage | <input type="text"/> | Seating Capacity | <input type="text"/> | Occupancy Number | <input type="text"/> |
| Number of Entrances | <input type="text"/> | Number of Exits | <input type="text"/> | Number of Floors | <input type="text"/> |

OCCUPANCY OF PREMISES

Please complete all fields in this section. Please provide proof of legal occupancy of the premises. (E.g. Deed, lease, letter of intent)

Please indicate by what means the applicant has to occupy the premises

Landlord Name

Landlord Phone

Landlord Email

Landlord Address

Lease Beginning Date

Rent per Month

Lease Ending Date

Rent per Year

Will the Landlord receive revenue based on percentage of alcohol sales? Yes No

8. AMENDMENT-Management Agreement

Management Agreement: (must fill out all pages in section 8)

Are you requesting approval to utilize a management company through a management agreement?
If yes, please fill out section 8.

Yes No

Please provide a narrative overview of the Management Agreement. Attach additional pages, if necessary.

IMPORTANT NOTE: A management agreement is where a licensee authorizes a third party to control the daily operations of the license premises, while retaining ultimate control over the license, through a written contract. *This does not pertain to a liquor license manager that is employed directly by the entity.*

8A. MANAGEMENT ENTITY

List all proposed individuals or entities that will have a direct or indirect, beneficial or financial interest in the management Entity (E.g. Stockholders, Officers, Directors, LLC Managers, LLP Partners, Trustees etc.).

| | | | | |
|--|--|--|--|--|
| Entity Name | Address | Phone | | |
| <input style="width: 95%;" type="text"/> | <input style="width: 95%;" type="text"/> | <input style="width: 95%;" type="text"/> | | |
| Name of Principal | Residential Address | SSN | DOB | |
| <input style="width: 95%;" type="text"/> | <input style="width: 95%;" type="text"/> | <input style="width: 95%;" type="text"/> | <input style="width: 95%;" type="text"/> | |
| Title and or Position | Percentage of Ownership | Director | US Citizen | MA Resident |
| <input style="width: 95%;" type="text"/> | <input style="width: 95%;" type="text"/> | <input type="radio"/> Yes <input type="radio"/> No | <input type="radio"/> Yes <input type="radio"/> No | <input type="radio"/> Yes <input type="radio"/> No |
| Name of Principal | Residential Address | SSN | DOB | |
| <input style="width: 95%;" type="text"/> | <input style="width: 95%;" type="text"/> | <input style="width: 95%;" type="text"/> | <input style="width: 95%;" type="text"/> | |
| Title and or Position | Percentage of Ownership | Director | US Citizen | MA Resident |
| <input style="width: 95%;" type="text"/> | <input style="width: 95%;" type="text"/> | <input type="radio"/> Yes <input type="radio"/> No | <input type="radio"/> Yes <input type="radio"/> No | <input type="radio"/> Yes <input type="radio"/> No |
| Name of Principal | Residential Address | SSN | DOB | |
| <input style="width: 95%;" type="text"/> | <input style="width: 95%;" type="text"/> | <input style="width: 95%;" type="text"/> | <input style="width: 95%;" type="text"/> | |
| Title and or Position | Percentage of Ownership | Director | US Citizen | MA Resident |
| <input style="width: 95%;" type="text"/> | <input style="width: 95%;" type="text"/> | <input type="radio"/> Yes <input type="radio"/> No | <input type="radio"/> Yes <input type="radio"/> No | <input type="radio"/> Yes <input type="radio"/> No |
| Name of Principal | Residential Address | SSN | DOB | |
| <input style="width: 95%;" type="text"/> | <input style="width: 95%;" type="text"/> | <input style="width: 95%;" type="text"/> | <input style="width: 95%;" type="text"/> | |
| Title and or Position | Percentage of Ownership | Director | US Citizen | MA Resident |
| <input style="width: 95%;" type="text"/> | <input style="width: 95%;" type="text"/> | <input type="radio"/> Yes <input type="radio"/> No | <input type="radio"/> Yes <input type="radio"/> No | <input type="radio"/> Yes <input type="radio"/> No |
| Name of Principal | Residential Address | SSN | DOB | |
| <input style="width: 95%;" type="text"/> | <input style="width: 95%;" type="text"/> | <input style="width: 95%;" type="text"/> | <input style="width: 95%;" type="text"/> | |
| Title and or Position | Percentage of Ownership | Director | US Citizen | MA Resident |
| <input style="width: 95%;" type="text"/> | <input style="width: 95%;" type="text"/> | <input type="radio"/> Yes <input type="radio"/> No | <input type="radio"/> Yes <input type="radio"/> No | <input type="radio"/> Yes <input type="radio"/> No |

CRIMINAL HISTORY

Has any individual identified above ever been convicted of a State, Federal or Military Crime?
If yes, attach an affidavit providing the details of any and all convictions.

Yes No

8B. EXISTING MANAGEMENT AGREEMENTS AND INTEREST IN AN ALCOHOLIC BEVERAGES LICENSE

Does any individual or entity identified in question 8A, and applicable attachments, have any direct or indirect, beneficial or financial interest in any other license to sell alcoholic beverages; and or have an active management agreement with any other licensees?

Yes No If yes, list in table below. Attach additional pages, if necessary, utilizing the table format below.

| Name | License Type | License Name | Municipality |
|------|--------------|--------------|--------------|
| | | | |
| | | | |
| | | | |

8. AMENDMENT-Management Agreement

8C. PREVIOUSLY HELD INTEREST IN AN ALCOHOLIC BEVERAGES LICENSE

Has any individual or entity identified in question 8A, and applicable attachments, ever held a direct or indirect, beneficial or financial interest in a license to sell alcoholic beverages, which is not presently held?

Yes No If yes, list in table below. Attach additional pages, if necessary, utilizing the table format below.

| Name | License Type | License Name | Municipality |
|------|--------------|--------------|--------------|
| | | | |
| | | | |
| | | | |

8D. PREVIOUSLY HELD MANAGEMENT AGREEMENT

Has any individual or entity identified in question 8A, and applicable attachments, ever held a management agreement with any other Massachusetts licensee?

Yes No If yes, list in table below. Attach additional pages, if necessary, utilizing the table format below.

| Licensee Name | License Type | Municipality | Date(s) of Agreement |
|---------------|--------------|--------------|----------------------|
| | | | |
| | | | |
| | | | |

8E. DISCLOSURE OF LICENSE DISCIPLINARY ACTION

Have any of the disclosed licenses listed in question 8B, 8C or 8D ever been suspended, revoked or cancelled?

Yes No If yes, list in table below. Attach additional pages, if necessary, utilizing the table format below.

| Date of Action | Name of License | City | Reason for suspension, revocation or cancellation |
|----------------|-----------------|------|---|
| | | | |
| | | | |
| | | | |

8F. TERMS OF AGREEMENT

- a. Does the agreement provide for termination by the licensee? Yes No
- b. Will the licensee retain control of the business finances? Yes No
- c. Does the management entity handle the payroll for the business? Yes No

d. Management Term Begin Date e. Management Term End Date

f. How will the management company be compensated by the licensee? (check all that apply)

- \$ per month/year (indicate amount)
- % of alcohol sales (indicate percentage)
- % of overall sales (indicate percentage)
- other (please explain)

ABCC Licensee Officer/LLC Manager

Signature:
 Title:
 Date:

Management Agreement Entity Officer/LLC Manager

Signature:
 Title:
 Date:

9. FINANCIAL DISCLOSURE

Required for the following transactions:

- Change of Officers, Stock or Ownership Interest (E.g. New Stockholder/Transfer or Issuance of Stock)
- Change of Premises Information
- Pledge of License, Inventory or Stock

Purchase Price(s):

| |
|------|
| None |
|------|

SOURCE OF CASH CONTRIBUTION

Please provide documentation of available funds. (E.g. Bank or other Financial institution Statements, Bank Letter, etc.)

| Name of Contributor | Amount of Contribution |
|---------------------|------------------------|
| N/A | |
| | |
| | |
| Total: | |

SOURCE OF FINANCING

Please provide signed financing documentation.

| Name of Lender | Amount | Type of Financing | Is the Lender a licensee pursuant to M.G.L. Ch. 138. |
|----------------|--------|-------------------|--|
| N/A | | | <input type="radio"/> Yes <input type="radio"/> No |
| | | | <input type="radio"/> Yes <input type="radio"/> No |
| | | | <input type="radio"/> Yes <input type="radio"/> No |
| | | | <input type="radio"/> Yes <input type="radio"/> No |

FINANCIAL INFORMATION

Provide a detailed explanation of the form(s) and source(s) of funding for the cost identified above.

| |
|-----|
| N/A |
|-----|

APPLICANT'S STATEMENT

I, Michael S. Gold the: sole proprietor; partner; corporate principal; LLC/LLP manager
Authorized Signatory
of Table & Vine, Inc
Name of the Entity/Corporation

hereby submit this application (hereinafter the "Application"), to the local licensing authority (the "LLA") and the Alcoholic Beverages Control Commission (the "ABCC" and together with the LLA collectively the "Licensing Authorities") for approval.

I do hereby declare under the pains and penalties of perjury that I have personal knowledge of the information submitted in the Application, and as such affirm that all statements and representations therein are true to the best of my knowledge and belief. I further submit the following to be true and accurate:

- (1) I understand that each representation in this Application is material to the Licensing Authorities' decision on the Application and that the Licensing Authorities will rely on each and every answer in the Application and accompanying documents in reaching its decision;
- (2) I state that the location and description of the proposed licensed premises are in compliance with state and local laws and regulations;
- (3) I understand that while the Application is pending, I must notify the Licensing Authorities of any change in the information submitted therein. I understand that failure to give such notice to the Licensing Authorities may result in disapproval of the Application;
- (4) I understand that upon approval of the Application, I must notify the Licensing Authorities of any change in the ownership as approved by the Licensing Authorities. I understand that failure to give such notice to the Licensing Authorities may result in sanctions including revocation of any license for which this Application is submitted;
- (5) I understand that the licensee will be bound by the statements and representations made in the Application, including, but not limited to the identity of persons with an ownership or financial interest in the license;
- (6) I understand that all statements and representations made become conditions of the license;
- (7) I understand that any physical alterations to or changes to the size of the area used for the sale, delivery, storage, or consumption of alcoholic beverages, must be reported to the Licensing Authorities and may require the prior approval of the Licensing Authorities;
- (8) I understand that the licensee's failure to operate the licensed premises in accordance with the statements and representations made in the Application may result in sanctions, including the revocation of any license for which the Application was submitted; and
- (9) I understand that any false statement or misrepresentation will constitute cause for disapproval of the Application or sanctions including revocation of any license for which this Application is submitted.
- (10) I confirm that the applicant corporation and each individual listed in the ownership section of the application is in good standing with the Massachusetts Department of Revenue and has complied with all laws of the Commonwealth relating to taxes, reporting of employees and contractors, and withholding and remitting of child support.

Signature: 
Title: VP, Secretary

Date: 10/2/23

Written Consent Vote of the Board of
Directors of
Table & Vine, Inc.

The undersigned, being all of the Directors of Table & Vine, Inc. (the "Corporation") acting without a meeting pursuant to Section 8.21 of Chapter 156D of the Mass. General Laws, hereby take the following action and adopt the following votes as of the date first set forth above:

RESOLVED: That this Corporation apply to the Licensing Authority of Northampton, Great Barrington, Holden, Franklin, Greenfield, Springfield, Wilbraham, West Springfield and Norwell and the Commonwealth of Massachusetts Alcoholic Beverages Control Commission for amendments to each of its Alcoholic Beverages Licenses relative to the Transfer of Stock/Change of Beneficial Interest in the Corporation's parent entity, Big Y Foods, Inc.; and

That Michael S. Gold, Vice President of the Corporation, is hereby authorized to sign the applications submitted and to execute on the Corporation's behalf, any necessary paperwork or documents, and to do all things required to have the applications granted.

Dated: September 15, 2023

Michael P. D'Amour, Director

Nicole D'Amour Schneider, Director

Christian D'Amour, Director

ADDITIONAL INFORMATION

Please utilize this space to provide any additional information that will support your application or to clarify any answers provided above.

A large, empty rectangular box with a thin black border, occupying the majority of the page below the text. It is intended for the applicant to provide additional information or clarify answers.

TOWN OF GREAT BARRINGTON

PUBLIC HEARING

The Great Barrington Selectboard will hold a public hearing on Monday, March 25, 2024 at 6:00 pm, at Town Hall, 334 Main Street, 2nd floor, Great Barrington, MA 01230, to act on the Special Permit application from Bear Mountain 320 Properties, Timberlyn Heights Care Center, to construct an addition on the existing nursing home at 320 Maple Avenue, Great Barrington, filed per Sections 3.1.4, B(10) and 10.4 of the Zoning Bylaw. The application may be viewed in Town Clerk's office.

To access a copy of the application and supplementary materials, [click here](#) to be redirected to a shared online PDF document.

From: [Mark Pruhenski](#)
To: [Josh Risen](#); [Natalie Amendola](#)
Subject: FW: Cable Franchise Renewal
Date: Monday, March 25, 2024 8:09:16 PM
Attachments: [PDF Town of Great Barrington license final 3 14 2024.pdf](#)

Can you drop this on the April 8th agenda and include the email and attached in the packet? Thanks!
-m

From: lzmillier-5towncac@roadrunner.com <lzmillier-5towncac@roadrunner.com>
Sent: Monday, March 25, 2024 3:09 PM
To: Mark Pruhenski <MPruhenski@Townofgb.org>
Cc: teehatch@gmail.com
Subject: Cable Franchise Renewal

****CAUTION:****
****This is an external email, be vigilant****
*****Do not click links or open attachments unless you recognize the sender (and their email address) and know the content is safe*****

After over 2 years of negotiations between Charter Communications/Spectrum and the Negotiations Sub-Committee of the Five Town Cable Advisory Committee, representing the Towns of Great Barrington, Lee, Lenox, Sheffield, and Stockbridge, an agreement has been reached on the terms and conditions of a Cable Television Franchise Renewal License, each with a term of 10 years, on behalf of the Five Towns.

Having met the requirements set forth by the Massachusetts Department of Telecommunications and Cable, having held the required public hearing, and had the draft reviewed, adjusted, and subsequently "signed off" by Counsel, The Five Town Cable Advisory Committee, on March 12th, 2024, voted unanimously in favor of its adoption by the Towns.

To execute the Great Barrington document, you must have the approval of your Board of Select Selectmen, and your subsequent sign off as Town Manager. It must also be signed off by Charter/Spectrum. In order to do so, you will need to send a signed copy of the signature page of the agreement to Charter.

Charter has requested that a .pdf copy of the executed agreement between Great Barrington and Charter Communications/Spectrum be sent to: Dan Reing, attorney for Charter, at DPreing@mintz.com, and Jennifer.R.Young@charter.com, State Director, Government Affairs, so that a .pdf of the full license agreement including signature page be emailed to them. They will send an indorsed signature page in return, thus completing the signing process.

Once approved and executed, a copy of Great Barrington's executed agreement is to be sent to, and filed with, the Massachusetts Department of Telecommunications and Cable.

If you have any questions, feel free to contact me.

Linda Z. Miller

Chairman

Five Town Cable Advisory Committee

Representing the Towns of Great Barrington,

Lee, Lenox, Sheffield and Stockbridge

(413)551-7014

April 2024

RE: Cable TV Renewal License Agreement with Spectrum Northeast LLC

We are delighted to let you know the Five Town Cable Advisory Committee (CAC) adopted the enclosed Cable TV Renewal License Agreement with Spectrum Northeast LLC at its meeting on March 12, 2024. This Agreement commences on February 28, 2023 and expires on February 28, 2033.

This adoption is the culmination of an Ascertainment Process, beginning with the CAC's official Ascertainment document issued on September 1, 2022 and mailed to you shortly thereafter. Direct CAC negotiations with Spectrum/Charter began January 18, 2023 and continued until November 29, 2023 with a total of eighteen negotiating sessions. Shortly after the holidays the Agreement was given to W. Hewig, Esq. of K-P Law for review and finalization of any identified issues directly with Spectrum.

As you know, the Ascertainment Process and resulting document involved extensive public input, with over 464 survey participants providing hundreds of comments and concerns and rating every aspect of their Cable TV experience, including billing, service, programming, cost, and resolution of complaints. Given this input and a statewide search of Cable TV license agreements signed all major service providers in Massachusetts, the appointed Five Town Cable Advisory Committee (CAC) Negotiations Subcommittee presented its own uniquely developed renewal license agreement to Spectrum. This renewal license agreement became the agreement from which all terms and conditions, and the enclosed Agreement, were negotiated.

The CAC negotiating subcommittee was able to strengthen this Agreement by the addition of several items, which were not included in the previous agreement with Time Warner Cable. Specifically, this Agreement includes for the first time:

- Process to convert PEG Access Channels to High Definition
- A Performance Bond
- Determination of Breach
- Statement of violations that are a Material Breach
- Liquidated Damages
- Quarterly License Fee Payments

And

- Stronger statement and process for Customer Complaints and Resolution, including increased accuracy in required State reporting
- Higher amounts of Licensee insurance coverage
- Stronger wording/clarity in almost all Sections of the 2013 contract
- \$212,000 for the PEG Access Capital Grant, payable in three payments

Two Sections we call your attention to are Section 5.7 PEG Access Capital Funding and Section 5.8 Method of Payment.

Massachusetts law has changed regarding how payments are now made from the Cable TV provider to the recipient Town. Whereas in years past, payments could be assigned by the Town to the PEG Access Corporation;

that is no longer allowed. In this contract, “All payments by the Licensee to the Town pursuant to this Renewal License shall be made payable to the Town and deposited with the Town Treasurer.”

Per the CAC’s counsel, Massachusetts law now requires that all funds from a Cable TV License are to be paid directly to the municipality. This includes the PEG Access Capital as well as quarterly License Fee payments. To move these funds to the PEG Access Provider will require appropriations, either on an annual or more frequent basis. Attorney Hewig cited two mechanisms for this: an Enterprise Fund pursuant to MGL C.44, §53 ½ or a PEG Access and Cable Related Fund, pursuant to MGL C. 44, §53 ¾.

Please consult with your Town Counsel for the warrant language required to transfer these funds from your Town Treasurer to the 5 Town’s Access Corporation, CTSB. (We expect to have an Access Corporation Agreement finalized with CTSB within the next 30 days.)

The negotiations with Spectrum Northeast LLC were long and at times challenging. However, both parties were respectful and open to the other side’s arguments and suggested Agreement language. The current Cable TV environment, with streaming channels and other media attracting previous cable TV customers, impacted these negotiations as it has made the market unstable and subject to uncertainty. While understanding the industry’s dynamics, the negotiating subcommittee delivered an improved, stronger, and more protective Agreement to the Five Towns.

The negotiating subcommittee followed all the Massachusetts Department of Telecommunications and Cable requirements, beginning with the Ascertainment Process and ending with the required Public Hearing on the draft Agreement at its December 2023 quarterly meeting.

Thank you in advance for your attention to this Agreement. When it has been properly signed, please send a .pdf of the entire contract to Charter, care of Charter’s attorney Dan Reing, DPreing@mintz.com , and also to Jennifer.R.Young@charter.com, Director, State Government Affairs; Charter Communications. They will send an endorsed signature page in return, thus completing the signing process. You then will need to send and file a completely executed agreement to the Massachusetts Department of Telecommunications and Cable.

Sincerely,

Rene Wood,
Sheffield’s representative to The Five Town Cable Advisory Committee

TOWN OF GREAT BARRINGTON

(For the Five Towns of Great Barrington, Lee, Lenox, Sheffield, and Stockbridge.)

**COMMONWEALTH OF MASSACHUSETTS
PROPOSED CABLE TELEVISION RENEWAL LICENSE**

Table of Contents

Preamble

ARTICLE 1: DEFINITIONS

ARTICLE 2: GRANT AND TERM OF RENEWAL LICENSE

Section 2.1 GRANT OF LICENSE

Section 2.2 RIGHTS AND PRIVILEGES OF LICENSEE

Section 2.3 APPLICABLE LAW

Section 2.4 TERM OF RENEWAL LICENSE

Section 2.5 TRANSFER AND ASSIGNMENT OF RENEWAL LICENSE

Section 2.6 EFFECT OF UNAUTHORIZED TRANSFER ACTION

Section 2.7 NON-EXCLUSIVITY OF RENEWAL LICENSE

Section 2.8 POLICE AND REGULATORY POWERS

Section 2.9 REMOVAL OR ABANDONMENT

Section 2.10 PROCEEDINGS UPON EXPIRATION OR REVOCATION OF RENEWAL LICENSE

ARTICLE 3: CABLE SYSTEM DESIGN, CONSTRUCTION, OPERATION, AND MAINTENANCE STANDARDS

Section 3.1 SUBSCRIBER NETWORK

Section 3.2 SERVICE AVAILABLE TO ALL RESIDENTS

Section 3.3 STRAND MAPS

Section 3.4 COMMERCIAL ESTABLISHMENTS

Section 3.5 EMERGENCY ALERT SYSTEM

Section 3.6 TREE TRIMMING AND CUTTING

Section 3.7 UNDERGROUND FACILITIES – DIG SAFE

Section 3.8 PEDESTALS

Section 3.9 RESTORATION TO PRIOR CONDITION

Section 3.10 COOPERATION WITH BUILDING MOVERS

Section 3.11 RELOCATION OF FACILITIES

Section 3.12 EMERGENCY REMOVAL OF CABLE SYSTEM

Section 3.13 RELOCATION OF FIRE ALARMS

Section 3.14 SERVICE INTERRUPTION

Section 3.15 RIGHT TO INSPECTION OF CONSTRUCTION

Section 3.16 CONSTRUCTION, UPGRADE, TECHNICAL, AND MAINTENANCE STANDARDS

Section 3.17 PRIVATE PROPERTY

Section 3.18 PROHIBITION OF WIRES FROM OBSTRUCTING ROAD OR FOOT TRAFFIC

ARTICLE 4: SERVICES AND PROGRAMMING

Section 4.1 BASIC CABLE SERVICE

Section 4.2 PROGRAMMING

Section 4.3 LEASED CHANNELS FOR COMMERCIAL USE

Section 4.4 FREE DROPS AND BASIC CABLE SERVICE TO PUBLIC BUILDINGS

Section 4.5 REMOTE CONTROL DEVICES

Section 4.6 REBATES DUE TO SERVICE INTERRUPTION

Section 4.7 CONTINUITY OF SERVICE

ARTICLE 5: LOCAL ACCESS PROGRAMMING: PUBLIC, EDUCATIONAL, AND GOVERNMENTAL (PEG) ACCESS CHANNELS, PROGRAMMING AND OPERATION

Section 5.1 PEG ACCESS CHANNELS

Section 5.2 ACCESS CORPORATION DESIGNATION

Section 5.3 PUBLIC ACCESS TO THE CABLE SYSTEM

Section 5.4 GOVERNMENT ACCESS TO THE CABLE SYSTEM

Section 5.5 EDUCATIONAL ACCESS TO THE CABLE SYSTEM

Section 5.6 FRANCHISE FEES

Section 5.7 PEG ACCESS CAPITAL FUNDING

Section 5.8 METHOD OF PAYMENT

Section 5.9 RECOMPUTATION

Section 5.10 EQUIPMENT OWNERSHIP

Section 5.11 REMOTE ORIGINATION POINTS

Section 5.12 PEG ACCESS CHANNELS MAINTENANCE

Section 5.13 CONVERSION OF PEG ACCESS CHANNELS OT HIGH DEFINITION

Section 5.14 CENSORSHIP

Section 5.15 ACCESS PROGRAMMING

Section 5.16 THIRD PARTY RIGHTS

Section 5.17 PEG ACCESS PROGRAMMING COSTS

ARTICLE 6: SUBSCRIBER RIGHTS AND CONSUMER PROTECTION

Section 6.1 CUSTOMER SERVICE OFFICE

Section 6.2 CUSTOMER SERVICE STANDARDS

Section 6.3 DEFINITION AND DOCUMENTATION OF CUSTOMER COMPLAINT

Section 6.4 COMPLAINT RESOLUTION PROCEDURES

Section 6.5 PRIVACY WRITTEN NOTICE

Section 6.6 SUBSCRIBER'S RIGHT TO PRIVACY, INSPECTION AND VERIFICATION OF INFORMATION

Section 6.7 PARENTAL CONTROL CAPABILITY

Section 6.8 BILLING AND TERMINATION PROCEDURES

Section 6.9 ADVANCE BILLING AND PAYMENT

Section 6.10 EMPLOYEE IDENTIFICATION CARDS

Section 6.11 NON-DISCRIMINATION

Section 6.12 INSIDE WIRING

Section 6.13 VOLUNTARY DISCONNECTION OF SERVICE

Section 6.14 ELECTRONIC NOTICE

ARTICLE 7: ADMINISTRATION, REGULATION, AND LICENSEE'S PERFORMANCE

- Section 7.1 REGULATORY AUTHORITY
- Section 7.2 INDEMNIFICATION
- Section 7.3 INSURANCE
- Section 7.4 PERFORMANCE BOND
- Section 7.5 NOTICE OF CANCELLATION OR REDUCTION OF COVERAGE
- Section 7.6 REPORTING
- Section 7.7 DETERMINATION OF BREACH
- Section 7.8 LIQUIDATED DAMAGES
- Section 7.9 MATERIAL BREACH
- Section 7.10 NO WAIVER – CUMULATIVE REMEDIES
- Section 7.11 PERFORMANCE EVALUATION HEARING
- Section 7.12 CABLE ADVISORY COMMITTEE
- Section 7.13 INFORMATION REQUESTS AND RIGHT TO INSPECT RECORDS AND FACILITIES
- Section 7.14 QUALITY OF SERVICE
- Section 7.15 FINANCIAL, COMPLAINT AND OTHER REPORTS
- Section 7.16 NON-EXCLUSIVITY OF REMEDY
- Section 7.17 DUAL FILINGS
- Section 7.18 TERMINATION

ARTICLE 8: GENERAL PROVISIONS

- Section 8.1 ENTIRE AGREEMENT
- Section 8.2 CAPTIONS
- Section 8.3 SEVERABILITY
- Section 8.4 FORCE MAJEURE
- Section 8.5 RENEWAL LICENSE EXHIBITS
- Section 8.6 WARRANTIES
- Section 8.7 APPLICABILITY OF RENEWAL LICENSE
- Section 8.8 JURISDICTION
- Section 8.9 NOTICE
- Section 8.10 TOWN'S RIGHT OF INTERVENTION
- Section 8.11 RESERVATION OF RIGHTS
- Section 8.12 INCORPORATION of M.G.L. c. 166A, § 5
- Section 8.13 NO THIRD-PARTY BENEFICIARIES
- Section 8.14 NO RECOURSE AGAINST THE ISSUING AUTHORITY

SIGNATURE PAGE

EXHIBITS

- Exhibit A: Town Service Area or Strand Map
- Exhibit B: Public Buildings to be Provided Basic Cable Service, and Local Origination Sites
- Exhibit D: Quarterly License Fee Payment Report
- Exhibit E: FCC Customer Service Obligations
- Exhibit F: 207 CMR 10.00: Billing and Termination of Cable Service

Preamble

This License Agreement (“License”) is between the Town of [*Insert the relevant Town: Great Barrington; Lee; Lenox; Sheffield; or Stockbridge*], hereinafter referred to as the “Town” or “Issuing Authority” and Spectrum Northeast, LLC, locally known as Charter or Spectrum, hereinafter referred to as the “Licensee.”

WHEREAS, Spectrum Northeast, LLC is a wholly owned in-direct subsidiary of Charter Communications, Inc.; and

WHEREAS, Spectrum Northeast, LLC, as the successor in interest to Time Warner Cable Northeast LLC, is the Licensee under the existing Cable Television License dated May 2013; and

WHEREAS, the Issuing Authority finds that the Licensee has substantially complied with the material terms of the current License under applicable laws, and that the financial, legal and technical ability of the Licensee is sufficient to provide services, facilities and equipment necessary to meet the future cable-related needs of the community; and

WHEREAS, having afforded the public adequate notice and opportunity for comment, the Issuing Authority desires to enter into this License with the Licensee for the construction and operation of a cable system on the terms set forth herein; and

WHEREAS, although the Issuing Authority has expressed interest in the Cable System carrying broadcast stations focused on Boston and Massachusetts news and sports, the Issuing Authority and the Licensee acknowledge that the Town is in the Albany-Schenectady-Troy Designated Market Area (“DMA”), not the Boston DMA, and determination of DMA boundaries is not within the control of either the Issuing Authority or the Licensee. Therefore, under federal law Licensee is obligated to carry broadcast stations from the Albany-Schenectady-Troy DMA, and cannot be obligated to carry broadcast stations from the Boston DMA. Nevertheless, Licensee will consider carrying broadcast stations from the Boston DMA if Licensee deems it to be technically and financially practicable and consistent with the company’s business objectives; and

WHEREAS, the Issuing Authority and Licensee have complied with all federal and State-mandated procedural and substantive requirements pertinent to this license renewal;

NOW, THEREFORE, the Issuing Authority and Licensee agree as follows:

ARTICLE 1 - DEFINITIONS

For the purpose of this License, the following words, terms, phrases, and their derivations shall have the meanings given herein, unless the context clearly requires a different meaning. When not inconsistent with the context, pronouns used shall be their or its, words used in the present tense include the future tense, words in the plural number include the singular number and words in the singular number include the plural number. The word shall is always mandatory and not merely directory.

Access: The right or ability of any Town resident and/or any Person affiliated with the Town to use designated Public, Educational, and Government (PEG) facilities, equipment, and or PEG Access channels of the Cable Television system, subject to the conditions and procedures established for such use.

Access Corporation: An entity designated by the Issuing Authority to manage and operate public, educational and governmental access (PEG) channels in the Town in accordance with this License and 47 U.S.C. 531. Currently, the Access Corporation is the non-profit corporation known as Community Television for The Southern Berkshires Inc. ("CTSB").

Advisory Committee: The Five Town Cable Advisory Committee ("CAC") as appointed and designated by the Issuing Authority, from time to time.

Affiliate or Affiliated Person: When used in relation to any Person this term shall have the meaning found in the Code of Massachusetts Regulations (CMR) 207 CMR 4.01(2), as may be amended, but currently meaning, any person or entity that directly or indirectly, or through one or more intermediaries, controls, is controlled by, or is under common control with another person or entity.

Amplifier: A device that boosts the strength of an electronic signal.

Basic Cable Service: Any service tier which includes the retransmission of local television broadcast signals and transmission of local PEG Access channels.

Cable Act: The federal Cable Communications and Policy Act of 1984, as amended by the Cable Television Consumer Protection and Competition Act of 1992, and subsequent amendments, 47 U.S.C. § 521 et seq.

Cable Service: The one-way transmission to Subscribers of Video Programming or other Programming Services, together with Subscriber interaction, if any, which is required for the selection of such Video Programming or other Programming Services.

Cable Television System or Cable System: Shall be defined herein as it is defined under Section 602(7) of the Cable Act, 47 U.S.C. 522(7), as may be amended, but currently meaning a facility, consisting of a set of closed transmission paths and associated signal generation, reception, and control equipment that is designed to provide cable service which includes video programming and which is provided to multiple subscribers within a community, but such term does not include (A) a facility that serves only to retransmit the television signals of one (1) or more television broadcast stations; (B) a facility that serves subscribers without using any public right-of-way; (C) a facility of a common carrier which is subject, in whole or in part, to the provisions of subchapter II of this chapter, except that such facility shall be considered a cable system (other than for purposes of 47 U.S.C. 541(c)) to the extent such facility is used in the transmission of video programming directly to subscribers, unless the extent of such use is solely to provide interactive on-demand services; (D) an open video system that complies with 47 U.S.C. 573; or (E) any facilities of any electric utility used solely for operating its electric utility system.

Channel: Shall be defined herein as it is defined under Section 602(4) of the Cable Act, 47 U.S.C. 522(4), as may be amended, but currently meaning a portion of the electromagnetic frequency spectrum which is used in a cable system and which is capable of delivering a television channel (as television channel is defined by the regulations of the Federal Communications Commission).

CMR: The Code of Massachusetts Regulations.

Commercial Subscriber: A commercial non-residential Subscriber to Cable Service.

Communications Act: The Communications Act of 1934, as amended, and located at 47 U.S.C. sec. 151 et seq.

Complaint: Shall be defined herein as it is defined by the Massachusetts Department of Telecommunications and Cable Division's Order Adopting Revised Form 500 (June 11, 1999), as may be amended, but currently meaning any written or verbal contact with the Licensee in connection with Cable Service in which a Person expresses dissatisfaction with an act, omission, product, or service that is (1) within the Licensee's control, and (2) requires a corrective measure on the part of the Licensee.

Conduit: An enclosed channel of metal or nonmetallic materials designed expressly for holding wires and cables, such as coax or fiber-optic cables.

Converter: An electronic device which converts Signals to a frequency acceptable to a television receiver of a Subscriber and permits a Subscriber to receive all Channels included in Subscriber's Cable Service.

Department: The Massachusetts Department of Telecommunications and Cable.

Distribution Plant or Plant: The hardware of a cable system, including, but not limited to, amplifiers, trunk cable and feeder lines, attached to utility poles or fed through underground conduits like telephone and electric wires.

Downstream Channel: A channel over which signals travel from the Cable System Headend to an authorized location within the System.

Drop or Cable Drop: The cable that connects an Outlet to the feeder cable of the Cable System.

Educational Access Channel: Any channel, which has been allocated for noncommercial educational use by the Town, Issuing Authority, or municipal agencies in accordance with this Agreement and 47 U.S.C. 531.

Effective Date of Renewal License (the "Effective Date"): The later date on which this document is signed by the Town of Great Barrington and Spectrum Northeast, LLC.

FCC: The Federal Communications Commission or any successor agency.

Feed line or Feeder line: Cable that connects trunk lines to drop cables.

Fiber: A transmission medium composed of glass or plastic fibers, rather than copper wire, used to transport data, video, and voice signals.

Franchise Fee: The payments made by the Licensee to the Issuing Authority, or its designee, which shall have the meaning set forth in 47 U.S.C. sec. 542 (g).

Governmental Access Channel: Any channel, which has been allocated for noncommercial, local governmental use by the Town, the Issuing Authority, or municipal agencies in accordance with this Agreement and 47 U.S.C. 531.

Gross Revenues: All revenues, as determined in accordance with generally accepted accounting principles ("GAAP"), derived by the Licensee and/or its Affiliates from the operation of the Cable System to provide Cable Service in the Town, including, without limitation, the following items: fees, charges and

payments collected from Subscribers (including Commercial Subscribers) for Cable Services, including, without limitation, Basic and premium Cable Services, video-on-demand Cable Services and pay-per-view Cable Services and digital Cable Services; installation, reconnection, downgrade, upgrade and similar charges; revenues received from rentals or leases to Subscribers of Converters, remote controls and other Subscriber equipment used to provide Cable Service over the Cable System; Leased Access Channel programming revenues; revenues that the Licensee receives from home shopping channels attributable to the Cable System in the Town; advertising revenues attributable to the Cable System in the Town; and except as provided below, all fees imposed on the Licensee by this Renewal License and applicable law that are passed through and paid by Subscribers ("fee-on-fee") in accordance with applicable law.

For the avoidance of doubt, Gross Revenues shall include the amount of the Licensee's gross advertising revenue, calculated in accordance with GAAP. Should any service provided by Licensee over the Cable System be classified as a Cable Service by a final determination or ruling of any agency or court having jurisdiction, after the exhaustion of all appeals related thereto, the Issuing Authority shall be entitled, after notification to Licensee, to amend this Renewal License in the manner prescribed under applicable State law or this Renewal License to include revenue from Licensee's provision of such service as Gross Revenue, and Licensee shall include revenue from such service as Gross Revenue on a going forward basis commencing with the next available billing cycle following the amendment date.

Gross Revenues shall not include: (a) Revenues received by any of the Licensee's Affiliates, except to the extent that such revenues relate directly to the provision of Cable Services over the Cable System in the Town; (b) Actual bad debts written off by the Licensee in the normal course of its business, provided, however, that bad debt recoveries shall be included in Gross Revenue during the period so collected; Any revenues foregone as a result of refunds, rebates or discounts made to Subscribers, or (c) the Licensee's provision of free or reduced cost Cable Services to any Person, including without limitation, employees of the Licensee and public institutions pursuant to M.G.L. Chapter 166A, Section 5(e); provided, however, that if the Licensee receives trades, barter, services or other items of value instead of cash revenue then such items shall be included in Gross Revenues; (d) Any revenues wholly generated by services that are defined and classified as Non-Cable Services revenue under federal or State law including, without limitation, revenues received from Telecommunications Services; revenues received from Information Services, and directory or Internet advertising revenue including, but not limited to, yellow page, white page, banner advertisement and electronic publishing; (e) Any revenues of the Licensee or any other Person which is received directly from the sale of merchandise through any Cable Service distributed over the Cable System, notwithstanding that portion of such revenue which represents or can be attributed to a Subscriber fee or a payment for the use of the Cable System for the sale of such merchandise, which portion shall be included in Gross Revenue; (f) Revenues from the sale of Cable Services on the Cable System to a reseller, when the reseller is required by the Town to pay (and does pay) License Fees to the Town on the resale of the Cable Services; (h) Any tax, fee or assessment of general applicability imposed by a Town, State, federal or other governmental entity and required to be collected from Subscribers by the Licensee and remitted to the taxing entity (including, but not limited to, taxes in the nature of a sales/use tax, communication tax and non-cable license fees); (i) Revenues from the sales of capital assets or sales of surplus equipment,; and (k) Any fees or charges collected from Subscribers for the PEG Access Capital Funding.

Headend: The electronic control center of the Cable System containing equipment that receives, amplifies, filters, and converts incoming Signals for distribution over the Cable System.

Issuing Authority: The Select Board of the Town of Great Barrington, Massachusetts.

Leased Channel or Leased Access: Any channel available for lease for programming by persons other than Licensee in accordance with Section 612 of the Cable Act, 47 U.S.C. sec. 532.

License: The non-exclusive grant by the Issuing Authority to the Licensee of authority to build, own, and operate a Cable System within the Town, represented by this instrument.

Licensee: Spectrum Northeast, LLC, or any successor or assignee in accordance with the terms and conditions in this Renewal License and all governing laws and regulations.

License Fee : The payment to be made by Licensee to the Issuing Authority on an annual basis which shall have the meaning as set forth in M.G.L. c. 166A, sec. 9.

M.G.L: Massachusetts General Law.

Normal Operating Conditions: Those service conditions which are within the control of the Licensee. Those conditions which are not within the control of the Licensee include, but are not limited to, natural disasters, civil disturbances, power outages, telephone network outages, and severe or unusual weather conditions. Those conditions which are ordinarily within the control of the Licensee include, but are not limited to, special promotions, pay-per-view events, rate increases, regular peak or seasonal demand periods, and maintenance or upgrade of the Cable System.

Origination Point or Origination Capacity: An activated connection to an Upstream Channel, allowing a User(s) to transmit a Signal(s) upstream to a designated location.

Outlet: An interior or exterior receptacle, generally mounted in a wall, through which cable service is provided to the customer.

Pay Cable or Premium Services: Programming delivered for a fee or charge to Subscribers on a per-channel or group of channels basis.

Pedestal: An environmental protection unit used in housing Cable System components.

PEG: Channel capacity designated for Public, Educational, and Governmental Access signals and available on all Cable Service, or Tiers, offered by the Licensee.

PEG Access: Any Licensee owned channel(s) made available by the Licensee and provided for use for the presentation of PEG Access Programming.

PEG Access Programming: Non-commercial Video Programming transmitted on the PEG Access Channel(s) pursuant to the terms of this Renewal License, and applicable laws.

Person: Any natural person or any association, firm, partnership, joint venture, corporation, limited liability company or other legally recognized entity, private or public, whether for profit or not-for-profit.

Public Access: The availability for non-commercial use by any resident, or any organization based in or serving the Town, of designated public access facilities, equipment, training and/or channels of the Cable Television System, as provided in this License and in accordance with 47 U.S.C. 531.

Public Access Channel: A specific channel(s) on the Cable System owned and made available by the Licensee to the Issuing Authority and/or the Access Corporation for use by, among others, the Town's residents and/or non-profit organizations wishing to present non-commercial Programming or information to the public.

Private Roads: Roads owned and maintained by private individuals or entities rather than by the Town or other government entity.

Public Way or Street: The surface of, as well as the spaces above and below, any and all public streets, avenues, highways, alleys, sidewalks, lanes, boulevards, concourses, driveways, bridges, tunnels, parks, parkways, and public grounds and all other publicly owned real property or real property rights under the jurisdiction of the Town within or belonging to the Town, or over which the Town has an easement or right-of-way, or easements or rights of way within the Town which have been dedicated for compatible uses in accordance with 47 U.S.C. 541 (a)(2), or to which the Town has rights compatible with the installation of cable and ancillary equipment pursuant to this License, now or hereafter existing. Reference herein to “Public Way” or “Street” is not to be construed to be a representation or guarantee by the Town that the Licensee shall gain or be permitted to exercise any rights to use property in the Town greater than those possessed by the Town.

Renewal License: The non-exclusive Cable Television License granted to the Licensee by this instrument.

Service Area: The area within the entire Town in which a residence can be served by a Standard Cable Installation from the cable plant as indicated on the map attached as Exhibit A.

Service Interruption: The loss of picture or sound on one or more Channels.

Signal: Any transmission of electromagnetic or optical energy which carries Programming from one location to another.

Standard Cable Installation: An aerial connection consisting of fiber and/or coaxial cable between the Trunk, Feeder Line and Distribution System and a residential or municipal governmental Outlet located within Two hundred fifty Feet (250') of the existing System's Trunk, Feeder Line and Distribution System, and which does not require design changes or additional equipment (including but not limited to amplifiers or plant extensions) to provide acceptable Signal quality into the residence.

State: The Commonwealth of Massachusetts.

Subscriber: Any Person, firm, corporation, or other entity who or which elects to subscribe to, for any purposes, a Cable Service provided or distributed by the Licensee by means of, or in connection with, the Cable Television System.

Subscriber Network: The bi-directional network owned and operated by the Licensee over which Signals are transmitted to subscribers, which shall meet or exceed all required FCC technological standards during the duration of this Renewal License.

Town: The Town of Great Barrington, Massachusetts including all area geography within the boundaries of the Town.

Towns: The Towns of Great Barrington, Lee, Lenox, Sheffield, and Stockbridge, Massachusetts.

Trunk: The major distribution cable used in cable television systems.

Trunk Line: As listed in the definition of Feed Line or Feeder Line

User: A person utilizing the Cable Television system, including all related facilities, for the purpose of production and/or transmission of PEG Access Programming as opposed to utilization solely as a Subscriber.

Video Programming or Programming: Programming provided by, or generally considered comparable to programming provided by, a television broadcast station.

ARTICLE 2 - GRANT AND TERM OF RENEWAL LICENSE

Section 2.1 GRANT OF LICENSE

Pursuant to the authority of Chapter 166A, §1 of the General Laws of the Commonwealth of Massachusetts and the Cable Act, and subject to the terms and conditions set forth herein, the Select Board of the Town of Great Barrington, acting as the Issuing Authority of the Town, hereby grants a non-exclusive, revocable Cable Television Renewal License to Licensee, authorizing and permitting Licensee to construct, upgrade, install, operate, and maintain a Cable Television System and provide Cable Service within the municipal boundaries of the Town.

Section 2.2 RIGHTS AND PRIVILEGES OF LICENSEE

Subject to the terms and conditions herein, the Issuing Authority hereby grants to Licensee, the right to construct, upgrade, install, operate, and maintain a Cable Television System in, under, over, along, across or upon the public streets, lanes, avenues, alleys, sidewalks, bridges, highways and other Public Ways or places in the Town within the municipal boundaries and subsequent additions thereto, including property over which the Town has an easement or right-of-way, or which the Licensee may use pursuant to 47 U.S.C. 541(a)(2), for the purpose of Cable Television System reception, transmission, collection, amplification, origination, distribution, or redistribution of audio, video, text, data or other signals in accordance with the laws of the United States of America, the Commonwealth of Massachusetts and the Town. In exercising rights pursuant to this License, Licensee shall not endanger or interfere with the lives of persons, interfere with any installations of the Town, any public utility serving the Town, nor unnecessarily hinder or obstruct the free use of public ways and places.

Section 2.3 APPLICABLE LAW

This Renewal License is granted under and in compliance with M.G.L. c. 166A and all other general laws and acts of the Massachusetts General Court, and in compliance with all applicable federal law, including, but not limited to the Cable Act, and all rules of the Federal Communications Commission (“FCC”), and all other State and federal rules and regulations. This Renewal License is subject to all rules and regulations of the Massachusetts Department of Telecommunications and Cable (“the Department”) and federal law.

Section 2.4 TERM OF RENEWAL LICENSE

This Renewal License shall commence upon the Effective Date, February 28, 2023, and shall expire on February 28, 2033, unless sooner terminated as provided herein or surrendered.

Section 2.5 TRANSFER AND ASSIGNMENT OF RENEWAL LICENSE

(a) Subject to applicable law, neither this Renewal License, or control thereof, shall be transferred, assigned, or disposed of in any manner, voluntarily or involuntarily, directly or indirectly, or

by transfer of control of any Person, company or other entity holding such Renewal License to any other Person, company, or other entity without the prior written consent of the Issuing Authority, which consent shall not be unreasonably or arbitrarily withheld. Such consent shall be given only after a public hearing, subject to fourteen (14) day duly published notice, upon receipt of a written application therefore on forms as may be prescribed by the Department or FCC. Any such consent process shall be consistent with the transfer requirements of M.G.L. c.166A, § 7; 207 CMR § 4.00 et seq.; the Cable Act; and FCC regulations, all as they may from time to time be amended. Any application for consent to a transfer or assignment, if required, shall be signed by the Licensee and by the proposed transferee or assignee, or by their authorized representatives, evidence of whose authority shall be submitted with the application.

(b) To the extent it is consistent with any governing federal or State law, a mortgage or other grant of a security interest in this Renewal License to a banking or other financial institution, or a pledge or grant of other security interest in the stock of Licensee to a banking or other financial institution, shall not be a transfer requiring consent of the Issuing Authority. Should such mortgagee or other holder of a security interest or pledgee assume control of the Cable Television System, such Issuing Authority consent shall be required in accordance with applicable law.

(c) To the extent it is consistent with any governing federal or state law, no consent under subsection (a) shall be required if such sale, assignment, or transfer is to an entity controlling, controlled by, or under common control with, the Licensee. For a proposed transfer that is not covered by the preceding sentence, on request of Licensee, the Issuing Authority, or on the Department's own initiative, the Department may determine whether or not a particular transaction shall be considered a transfer or assignment or change of control thereof under M.G.L. c. 166A, § 7, for which consent under subsection (a) is necessary. The Issuing Authority must be notified of any such request made by Licensee to the Department, and the Department's ultimate determination, which shall be binding on the Licensee and Issuing Authority.

(d) Subject to all applicable laws and regulations, in considering a request to transfer control of this Renewal License, the Issuing Authority may consider such factors as the transferee's financial, legal, and technical performance qualifications, as allowable under applicable federal or state laws or regulations, and request such reasonable information as allowable under applicable law or regulations.

(e) For purposes of Section 2.5, the word "control" shall comply with the definition of such in 207 CMR 4.01.

(f) The consent or approval of the Issuing Authority to any assignment, lease, transfer, sublease, or assumption of control by a mortgagee of the Renewal License granted to the Licensee shall not constitute a waiver or release of the rights of the Town in and to the streets and Public Ways or any other rights of the Town under this Renewal License, and any such transfer shall, by its terms, be expressly subordinate to the other terms and conditions of this Renewal License.

(g) The Licensee shall submit to the Issuing Authority an original and one (1) copy, unless otherwise required, of the application and FCC Form 394 requesting such transfer or assignment consent.

(h) Unless otherwise allowed by applicable law(s), the Issuing Authority shall make a decision on said written application within one hundred and twenty (120) days of receipt of said application. After 120 days, the application shall be deemed approved, unless said 120-day period is extended by mutual written consent of the parties.

(i) Any proposed controlling or owning Person or transferee approved by the Issuing Authority shall be subject to all of the terms and conditions contained in this Renewal License and so agrees with and by their signature to the transfer or assignment document.

Section 2.6 EFFECT OF UNAUTHORIZED TRANSFER ACTION

(a) Any transfer of the Cable System without complying with Section 2.5 above or with any federal or state law or regulation, shall be deemed a material breach of this Renewal License; and among other remedies available to the Town, be subject to liquidated damages assessment in Section 7.8 infra.

(b) If the Issuing Authority denies its consent to any such action and a transfer has nevertheless been affected, the Issuing Authority may revoke and terminate the Renewal License in accordance with the procedures outlined in Section 7.7 herein, unless such transfer is otherwise allowable by applicable law.

(c) The grant or waiver of any one or more of such consents shall not render unnecessary any subsequent consent or consents, nor shall the grant of any such consent constitute a waiver of any other rights of the Town.

Section 2.7 NON-EXCLUSIVITY OF RENEWAL LICENSE

This Renewal License shall not affect the right of the Issuing Authority to grant to any other Person, a license or right to occupy or use the Public Ways, or portions thereof, for the construction, installation, operation, or maintenance of a Cable Television System within the Town or the right of the Issuing Authority to permit the use of the Public Ways for any purpose whatsoever. If the Issuing Authority grants any other Person such a license, the Issuing Authority shall amend this License, following the procedures set forth in 207 C.M.R. sec. 3.07, upon request by Licensee, to ensure that the obligations applicable to Licensee are no more burdensome or less favorable than those imposed in the license granted to the new Person by the Issuing Authority.

In the event any change to state or federal law occurring during the term of this Renewal License materially alters the regime of cable licensing applicable to any Persons desiring to construct, operate or maintain a Cable Television System in the Town in a way that reduces the regulatory or economic burdens for such Person when compared to the terms of this Renewal License, then, Licensee shall have the right to avail itself of the options provided for thereunder, or at Licensee's written request, the Issuing Authority shall agree with Licensee to amend this Renewal License as provided at 207 CMR § 3.07 et seq. to similarly reduce the regulatory or economic burdens on Licensee.

Section 2.8 POLICE AND REGULATORY POWERS

Licensee acknowledges that its rights are subject to the Town's right to adopt and enforce generally applicable by-laws, laws, and regulations in the lawful exercise of its police powers to the full extent permitted by law, with respect to the safety and welfare of the public. The Licensee shall comply with all applicable Town by-laws and lawful regulations, provided such are of general applicability and not specific to this License, the Licensee and/or Cable System. In the event of any conflict between this License and any Issuing Authority's by-laws, laws, or regulations, apart from the lawful police powers of the Town, materially contradicting the applicable provisions of this License, the terms of this License shall prevail, to the extent there is a dispute as to the existence of a conflict the parties shall meet and confer to resolve the issue.. This License is a contract and except as to those changes, which are the result of the Issuing Authority's exercise of its general police power, neither party may take any unilateral action, which materially changes the mutual promises in this contract. Any changes to this License shall be made according to Section 8.1.

Section 2.9 REMOVAL OR ABANDONMENT

Pursuant to M.G.L. c. 166A, § 5(f), and subject to federal law, including in particular the Cable Act, upon termination of this Renewal License by passage of time or otherwise without right of renewal, and unless Licensee renews its Renewal License for another term, transfers its License to a transferee approved by the Issuing Authority, or the Issuing Authority approves the Cable System remaining in place, Licensee shall remove its supporting structures, poles, trunk and distribution system, and all other facilities from the Public Ways and places and shall restore all areas to their original condition. If such removal is not completed within six (6) months after such termination, the Issuing Authority may deem any property not removed as having been abandoned. Any disposal of such abandoned property shall be in accordance with Massachusetts law and if the Issuing Authority removes such abandoned property, it shall do so at Licensee's sole expense.

Section 2.10 PROCEEDINGS UPON EXPIRATION OR REVOCATION OF RENEWAL LICENSE

In the event this Renewal License is revoked or that it expires without renewal, the Issuing Authority and the Licensee may transfer the Cable System to the Town or a subsequent Licensee subject to Section 627 of the Cable Act, 47 U.S.C. sec. 547.

**ARTICLE 3 – CABLE SYSTEM DESIGN, CONSTRUCTION, OPERATION,
AND MAINTENANCE STANDARDS**

Section 3.1 SUBSCRIBER NETWORK

(a) The Licensee will maintain a Cable Television System, which meets or exceeds all required FCC technological standards, including but not limited to 47 CFR sec. 76.601, subpart K et seq., during the duration of this Renewal License.

(b) The Licensee shall continue to maintain throughout the term of this Renewal License, twenty-four hour, standby power at the Headend facility(ies) and any sub-headends. Such stand-by power shall provide continuous capability, contingent upon availability of fuel necessary to operate generators, and shall become automatically activated upon the failure of the Licensee's normal power supply.

(c) The system design of the Cable Television System and Subscriber Network shall, at all times throughout this Renewal License, meet all applicable FCC technical standards and all applicable technical specifications contained in this Renewal License.

Section 3.2 SERVICE AVAILABLE TO ALL RESIDENTS

(a) The Licensee shall make its Cable Service available to substantially all residents of the Town, regardless of type of dwelling or its geographical location in the Town subject to Section 3.2(b)-(f) below, unless the Licensee is legally prevented from providing such Cable Service.

(b) The Licensee shall install Cable Service within fourteen (14) days of a request at a Standard Cable Installation charge to any residence in the Service Area currently served by the Cable System as indicated on the map attached as Exhibit A, (and as it may be supplemented upon additions to the plant) except that Licensee may charge for the costs of labor and materials necessary to provide service beyond two hundred and fifty feet (250') from the Cable System in the public way and/or to provide a customized installation, including any undergrounding, boring, or trenching. For purposes of this Section, private roads (i.e., roads not serviced by the Town) are not in the public way.

(c) In order to fulfill a request for cable service to a residence, the Cable System shall be extended at Licensee's expense, from existing Cable Plant to any and all areas of the Town containing twenty (20) residences per aerial mile of cable plant or fractional proportion thereof necessary to provide service. Said service shall be made available and fully activated to requesting subscribers no later than sixty (60) days after the Licensee's receipt of permission to attach cable to poles. Density per aerial mile of Cable System shall be computed by dividing the number of residential dwelling units within 250 feet of the plant to be installed by the length, in miles or fractions thereof, of the total amount of new construction of aerial cable necessary to make service available to the residential dwelling units in such area in accordance with Licensee's system design parameters. The cable length shall be measured from the nearest point of access to the then-existing Cable System, provided such extension is technically feasible from that point of access and located within the public rights-of-way. The total cable length shall exclude the drop cable necessary to serve individual subscriber premises.

(d) The Cable Television System shall be further extended to all areas in the Town that do not meet the requirements of subsections (b) or (c) above upon request of the prospective subscribers in such areas and based upon the following cost calculation: If a request for an extension requires the construction of the Cable System into an area which does not contain the twenty (20) residences per aerial mile of cable plant or a fractional part thereof, the Licensee and the potential subscriber(s) will each be responsible for their proportionate share of construction costs.

(e) When the Licensee has forty-five (45) days prior notice concerning the opening of residential subdivision trenching, or of the standard installation of conduit for the location of utilities, it shall install its cable in such trenching or conduits or may seek permission to utilize alternative trenching or conduits within a comparable time frame; provided that such residential subdivision meets the density requirement of subsection (c) above, or has an actionable request for service pursuant to subsection (d) above.

(f) The Licensee shall expeditiously seek all necessary permits.

Section 3.3 STRAND MAPS

Within forty-five (45) days after a written request to the Licensee, the Licensee shall, without charge, make available to the Issuing Authority for inspection accurate and readily readable strand maps of all existing and newly constructed Cable System plant at the closest Licensee's business office. The Town agrees to maintain the confidential nature of such maps. However, consistent with the definition of Service Area, Licensee shall upon request of the Issuing Authority or their delegate, update annually on January 15th strand maps to reflect additional cable plant (except drops) installed over the past year. Such updates shall be available for inspection to the Town, in accordance with the procedures noted herein.

Section 3.4 COMMERCIAL ESTABLISHMENTS

The Licensee may make Cable Service(s) available to any commercial, not-for-profit, or non-profit establishment(s) in the Town provided that such establishment(s) agrees to pay for the installation and monthly subscription costs as established by the Licensee. It is herein acknowledged that certain programming service may not be available to commercial establishments pursuant to applicable law or the Licensee's agreements with programmers.

Section 3.5 EMERGENCY ALERT SYSTEM

The Licensee's Subscriber Network shall comply with the FCC's Emergency Alert System ("EAS") Regulations, 47 CFR 11, et seq.

Section 3.6 TREE TRIMMING AND CUTTING

In the installation, maintenance, operation, and repair of the poles, cables, wires and all appliances or equipment of the Cable System, the Licensee shall avoid all unnecessary damage and injury to any and all shade trees whether in the Public Way or on private property and shall cut or otherwise prune such trees only to the least extent necessary. Licensee shall comply with all applicable regulations regarding trimming and cutting of trees. Licensee shall make reasonable efforts to secure the permission of the Town or property owner prior to any reasonable tree trimming.

Section 3.7 UNDERGROUND FACILITIES – DIG SAFE

Upon receiving due notice of the installation of telephone, electric and all other utility lines underground, the Licensee shall likewise place its facilities underground. Underground cable lines shall be placed according to any Public Works, Highway Department or other Town by-law or regulation and in accordance with applicable state law. It is the policy of the Town that existing poles for electric and communication purposes be utilized wherever possible if available on reasonable terms and that underground installation is preferable to the placement of additional poles, provided that said underground placement is required of other utilities. When possible, Licensee may use the underground conduit maintained by the Town provided that such use (i) is found by the Issuing Authority to be reasonable and at the sole cost and expense of the Licensee; and (ii) does not interfere with the Town's use or anticipated use of said conduit(s). Any such use by the Licensee shall be subject to the advance notification and approval of the Town and the right of the Town to supervise any such use. Licensee shall maintain membership and participate in the Massachusetts "DIG-SAFE" program and shall comply with all applicable "dig-safe" provisions, pursuant to M.G.L. c. 82, § 40.

Section 3.8 PEDESTALS

In any case in which pedestals housing passive or active devices are to be utilized in the Town Public Ways or within the Town public lay-out, such equipment shall be placed in a low-profile, above-ground electronic control box in accordance with applicable regulations, and at Town approved locations to be determined when Licensee applies for a permit, which will not be unreasonably denied.

Section 3.9 RESTORATION TO PRIOR CONDITION

(a) Whenever the Licensee takes up or disturbs any pavement, sidewalk, or other improvement of any Public Way or public place, the same shall be replaced, and the surface restored in as good condition as before entry and to such standards required of utilities operating within the Town and as soon as practicable. If the Licensee fails to make such restoration within a reasonable time, the Issuing Authority may notify the Licensee in writing of the required restoration and the reasonable time for completion of the restoration. Upon failure of the Licensee to comply with the time specified, the Issuing Authority may cause proper restoration and repairs to be made and the expense of such work shall be paid by the Licensee upon demand by the Issuing Authority. Any damages to private property shall be determined in accordance with M.G.L. c. 166A, § 22 and applicable law.

(b) Underground crossings of paved roads will be by boring under the road, not by trenching or opening the surface of the road except to the extent that boring is not feasible or is otherwise unreasonable to do.

Section 3.10 COOPERATION WITH BUILDING MOVERS

The Licensee shall temporarily raise or lower its wires or other equipment upon the reasonable request of any Person, including without limitation, a Person holding a building moving permit issued by

the Town. The expense of such raising or lowering shall be paid in advance by the Person(s) holding the building move permit, and without charge to the Town. The Licensee shall be given reasonable notice necessary to maintain continuity of service, which notice shall be no less than 60 days.

Section 3.11 RELOCATION OF FACILITIES

The Licensee shall, upon receipt of reasonable advance written notice, to be not less than ten (10) business days, temporarily or permanently relocate any part of the Cable System when required to do so by the Town for good reasons, which are within the Town's police power, such as public safety, street construction, change or establishment of street grade or layout, installation of sewers, drains, water pipes, power, or signal lines, setting of new or replacement utility poles and the construction of any public improvement or structure. Licensee shall be responsible for any costs associated with such relocation to the same extent all other users of the Town's rights-of-way are responsible for the costs related to the relocation of their facilities.

Section 3.12 EMERGENCY REMOVAL OF CABLE SYSTEM

If, at any time, in case of fire or disaster in the Town, it shall become necessary in the exercise of police powers of the Issuing Authority or any public safety or other designated public official, to adjust, move or remove any of the wires, cables, amplifiers, appliances, or appurtenances of the Cable System, the Town shall have the right, within its police power, to do so at the sole cost and expense of the Licensee. In such case, the Town shall notify Licensee of the cables or other equipment which have been adjusted, moved, or removed.

Section 3.13 RELOCATION OF FIRE ALARMS

The Licensee shall reimburse the Town at cost for any reasonable expense including materials and labor caused by the relocation of any fire alarm, cable, or equipment to make poles ready for the Licensee's Cable System. The Town shall cooperate in this relocation so as to minimize delay in Licensee's construction schedule.

Section 3.14 SERVICE INTERRUPTION

Except where an emergency situation necessitates a more expeditious procedure, Licensee shall use reasonable efforts to avoid the interruption of service for the purpose of system construction, routine repairing or testing the Cable System and only do so during periods of minimum use.

Section 3.15 RIGHT TO INSPECTION OF CONSTRUCTION

(a) The Issuing Authority or its designee(s) shall have the right, upon reasonable advance written notice, to inspect construction and installation work performed subject to the provisions of this Renewal License, as it shall deem necessary to ensure compliance with the material terms and conditions of this Renewal License. Any such inspection(s) shall not interfere with the Licensee's operations, except in emergency situations.

(b) Any inspection conducted by the Issuing Authority, or its designee(s), shall be at the sole cost and expense of the Issuing Authority or its designee(s) and the Licensee shall be afforded the opportunity to be present during all such inspections.

Section 3.16 CONSTRUCTION, UPGRADE, TECHNICAL, AND MAINTENANCE STANDARDS

(a) The Licensee shall operate and extend a Cable System and render efficient service to Subscribers as required by this Renewal License and applicable laws and regulations during the term

of this Renewal License. The construction, maintenance and operation of the Cable System for which this Renewal License is granted shall be in conformance with all applicable provisions of the Massachusetts Electrical Code, the National Electrical Safety Code, all applicable rules and regulations of the Occupational Safety and Health Administration (OSHA), the Department, the Department of Public Utilities, the FCC and all State and generally applicable Town building and zoning codes and all land use restrictions, as they may from time to time be amended. All FCC regulations concerning technical standards are incorporated as independent standards of this Renewal License as well, including but not limited to 47 CFR 76.601 sub-part K, et seq.

(b) Copies of any technical performance tests required under FCC rules and regulations shall be submitted within 30 days of a written request and at no charge to the Issuing Authority. The Licensee's Cable System shall incorporate a technically advanced design configuration and operation consistent with standard cable industry practices.

(c) If, as a result of technological development(s), the Licensee's Cable System could be enhanced, the Licensee shall investigate the feasibility of implementing such new development(s) and shall implement such technological development(s) if such implementation (i) can be done without adding a financial burden to subscribers and (ii) is technically and economically feasible and viable for the Licensee as determined by Licensee. However, the Licensee shall not avoid implementing any and all system or technological standards as lawfully required by the FCC, or by any other agency or regulatory authority identified above in sec. 3.16 (a), during this Renewal License period. In determining whether or not the Licensee shall implement such new development(s), the Licensee will consider, among other factors, the remaining term of this Renewal License; performance demonstrating the operational feasibility of the new development(s); construction and other related costs; the adaptability of such development(s) to the Licensee's Cable System or any part thereof; the potential marketability of the new service(s) and other factors affecting the economic feasibility and viability of implementation of the new development(s); and adoption of such new development(s) by neighboring communities.

(d) The Licensee shall maintain audio variations within its control between channels in the Cable System in accordance with FCC Technical Standards.

(e) All Licensee's structures, lines, equipment, and connections in, over, under, and upon streets, sidewalks, alleys, and public ways and places of the Town, wherever situated or located, shall at all times be kept and maintained in a safe condition and in good order and repair.

Section 3.17 PRIVATE PROPERTY

The Licensee shall be subject to all applicable laws, by-laws, or regulations regarding private property in the course of constructing, upgrading, installing, operating, and maintaining the Cable Television System in the Town including, but not limited to, M.G.L. c .166A, § 22, as it may from time to time be amended.

Section 3.18 PROHIBITION OF WIRES FROM OBSTRUCTING ROAD OR FOOT TRAFFIC

The Licensee shall at all times maintain its wires in such condition as not to interfere with road or foot traffic. Licensee shall periodically inspect all wires to ensure that this requirement is strictly and continually met. Low wires obstructing road or foot traffic, or loose or disconnected wires shall be corrected, replaced or removed immediately upon discovery, or upon a report to Licensee from any source. Any such report shall be considered a Complaint within the meaning of this License.

ARTICLE 4 – SERVICES AND PROGRAMMING

Section 4.1 BASIC CABLE SERVICE

Subject to applicable law, the Licensee shall make available a Basic Cable Service to all Town Subscribers, that shall include at least the Designated Market Area (“DMA”) broadcast television signals the Licensee carries as required by Federal law, and the downstream channels for public, educational, and governmental (PEG) access use.

Section 4.2 PROGRAMMING

In accordance with applicable federal law, the Licensee shall provide the Issuing Authority and all Subscribers with notice of its intent to substantially change the Town’s Programming line-up. Such notice shall be provided at least thirty (30) days before any substantial change is to take place, unless the change results from circumstances outside the Licensee’s control, in which case notice shall be provided as soon as possible using any reasonable written means at the Licensee’s sole discretion.

Section 4.3 LEASED CHANNELS FOR COMMERCIAL USE

Pursuant to Section 612(b)(1)(B) of the Cable Act, 47 U.S.C. sec. 532, the Licensee shall make available channel capacity for commercial use by Persons unaffiliated with the Licensee.

Section 4.4 FREE DROPS AND BASIC CABLE SERVICE TO PUBLIC BUILDINGS

(a) The Licensee shall voluntarily provide and maintain, at no charge, an activated Subscriber Standard Cable Installation, Outlet, Converter, and the monthly Basic Cable Service to all public libraries; police and fire stations; Town Hall; Senior Center; and Public Schools as identified in Exhibit B hereto. Such locations listed on Exhibit B and receiving service as of the Effective Date, shall continue to receive such service regardless of the length of the existing drop. Such service shall continue without charge on a voluntary basis. To the extent Licensee’s management ceases its voluntary municipal service program, Licensee will provide the Town with at least one hundred twenty (120) days advance written notice of its intent to cease the program and the rate it proposes to charge, to allow the parties to negotiate whether the Town wishes to continue receiving such service at such locations and the appropriate rate for such service should the Town decide to continue receiving such service. The rate that Licensee may charge the Town for such service shall be outlined in an agreement between the parties and in accordance with applicable law and regulation.

(b) The Licensee shall coordinate the precise location of each Drop and Outlet with proper officials in each of the buildings or institutions prior to any installation.

(c) During the term of this License, or any such agreement reached pursuant to Sec. 4.4 (a) above, and upon ninety (90) days’ written notice to Licensee, the Issuing Authority may request additional facilities or relocate current facilities for the provision of Cable Service and equipment as described above, provided that each new location can be serviced with a Standard Cable Installation and meets the requirements of Licensee’s voluntary municipal program.

Section 4.5 REMOTE CONTROL DEVICES

To the extent required by applicable law, the Licensee shall allow Subscribers to purchase from parties other than the Licensee and to utilize remote control devices that are compatible with the converter box installed by the Licensee.

Section 4.6 REBATES DUE TO SERVICE INTERRUPTION

In accordance with M.G.L. c. 166A, § 5(l), the Licensee shall grant a pro-rata credit or rebate to any Subscriber whose entire Cable Service is interrupted for twenty-four (24) or more consecutive hours if the interruption was not caused by the Subscriber and the Licensee knew or should have known of the Cable Service interruption. If an entire tier or premium service of a Subscriber's Cable Service is interrupted for twenty-four (24) or more consecutive hours, the Licensee shall provide a pro-rata credit or rebate for each tier or premium Cable Service interruption.

Section 4.7 CONTINUITY OF SERVICE

It shall be the right of all subscribers to continue receiving Cable Service insofar as their financial and other obligations to the Licensee are honored; provided, however, that the Licensee shall have no obligation to provide Service to any Person the Licensee has a reasonable basis to believe is utilizing an unauthorized converter or is otherwise obtaining any Cable Service without required payment thereof.

ARTICLE 5 - LOCAL ACCESS PROGRAMMING: PUBLIC, EDUCATIONAL, AND GOVERNMENTAL (PEG) ACCESS CHANNELS, PROGRAMMING, AND OPERATION

Section 5.1 PEG ACCESS CHANNELS

(a) Upon the Effective Date of this Renewal License, the Licensee shall continue to make available a total of three (3) licensee-owned Subscriber Network channels for PEG Access purposes, which shall be used to transmit non-commercial PEG Programming to Subscribers and, except as otherwise provided for herein, shall be subject to the control and management of the Town and the Access Corporation. Subject to applicable law, said Access Channels shall be included in the Licensee's Basic Cable Service.

(b) All PEG Access Channels transmitted to Licensee by the Access Corporation with closed captioning will be broadcast with closed captioning to the extent required by applicable law.

(c) As of the Effective Date of this Renewal License, the PEG Access channel locations are as follows: (i) Public Access: Channel 1301; (ii) Educational Access: Channel 1302; and (iii) Governmental Access: Channel 1303.

(d) The Licensee shall not move or otherwise relocate the channel locations of any PEG Access channel(s), without advanced written notice to the Issuing Authority. Such written notice shall be provided at least thirty (30) days in advance unless Licensee is legally mandated by the FCC or the Department to move a PEG Access channel(s) sooner.

Section 5.2 ACCESS CORPORATION DESIGNATION

The Issuing Authority shall authorize an Access Corporation to provide services to Public, Educational, and Governmental Access users. Such authorization shall be set forth in a separate agreement between the Issuing Authority and the selected Access Corporation.

Section 5.3 PUBLIC ACCESS TO THE CABLE SYSTEM

Any resident of the Town, or any non-commercial organization based in or servicing the Town, shall have the right to place programming on the PEG Access channel dedicated to public use subject to any rules or policies established by the Town or the Access Corporation. The parties recognize that any PEG Access channel facilities, equipment, and training will be available on a shared basis to each of the Towns pursuant to their respective Renewal Licenses.

Section 5.4 GOVERNMENT ACCESS TO THE CABLE SYSTEM

Any PEG Access channel provided herein and dedicated to Government Access shall be available to the Issuing Authority for the purposes of non-commercial municipal access television programming in accordance with 47 U.S.C. 531. Such channel may be used by government departments and agencies to inform subscribers about the Town, or other government unit, and its services. Government Access programming shall be coordinated and managed by the Access Corporation, unless the Town decides to operate Government Access under a government department.

Section 5.5 EDUCATIONAL ACCESS TO THE CABLE SYSTEM

Any PEG Access channel provided herein and dedicated to Educational Access use shall be available to any School, or School District, serving the Town for the purposes of non-commercial Educational Access television programming in accordance with 47 U.S.C. 531. Educational Access programming shall be coordinated and managed by the Access Corporation in cooperation with any such School or School District.

Section 5.6 FRANCHISE FEES

(a) The Licensee shall continue to pay to the Issuing Authority, throughout the term of this Renewal License, a Franchise Fee equal to five percent (5%) of the Licensee's Gross Annual Revenues, as such term is defined in this Renewal License, less the amount paid by Licensee under Section 5.6(g) below. Said Franchise Fee shall be used for, among other things, support of the Access Corporation, PEG Access programming, and for any other purpose allowed by law.

(b) Funding provided by the Licensee hereunder shall be paid in accordance with Section 5.6 (c) below; provided, however, that if the license or renewal license of another cable operator (or its successor or assign) in the Town, provides for such operator to pay a lower percentage during such time period, then the percentage of the Licensee's Franchise Fee shall be reduced to match such lower percentage over that same time period.

(c) The Franchise Fee payments, pursuant to Section 5.6(b) above, shall be made no later than forty-five (45) days following the end of each calendar quarter. Upon request, Licensee shall provide a Gross Revenues Report Form and Calculation of Quarterly Franchise Fee Payment in the form of (or substantially similar to) Exhibit C. For purposes of this Section 5.6(c), the period for determining Gross Revenues shall be the preceding calendar quarter.

(d) In the event that the Franchise Fees herein required are not tendered on or before the date fixed in Section 5.6(c) above, interest due on such fee shall accrue from the date due at the Prime Rate.

(e) The Licensee shall not be liable for a total financial commitment pursuant to this Renewal License and applicable law in excess of five percent (5%) of the Licensee's Gross Annual Revenues; provided, however, that said five percent (5%) shall include any License fee payable to the FCC and the State; and furthermore provided, however, that said five percent (5%) shall not include the following: (i) the PEG Access capital grants herein (Section 5.7); (ii) any interest due to the Town because of late payments; (iii) any damages herein (Section 7.8); and (iv) any taxes or other fees or charges which the Licensee shall be required to pay to the Town or any State or federal agency or authority.

(f) Unless otherwise required by applicable law, if services included within the definition of Gross Annual Revenues are provided to subscribers in conjunction with services not within such definition for a single aggregate price, and the total cost of such bundled services reflects a discount from the aggregate retail prices of the services contained therein when provided separately, the five percent (5%) Franchise Fee shall be calculated in accordance with GAAP.

(g) Subject to applicable law, Licensee shall, on or before March 15th of each year, submit a License fee to the Issuing Authority equal to fifty cents (\$.50) per subscriber per year as provided in Page 20 of 50

M.G.L. c. 166A, § 9. The number of subscribers, for purposes of this Section, shall be calculated on the last day of each calendar year.

Section 5.7 PEG ACCESS CAPITAL FUNDING

(a) The Licensee shall provide a monetary grant to be used for capital purposes for the benefit of the Access Corporation, and in support of the production of PEG Access Channel programming (the “PEG Access Capital Grant”) throughout the Five Towns. A PEG Access Capital Grant in the total amount of \$212,000 provided by Licensee shall be paid in three instalments as follows: One Hundred Fifty Thousand Dollars (\$150,000) will be paid no more than ninety (90) days after all Five Towns have executed this Renewal License; Thirty-One Thousand Dollars (\$31,000) will be paid no more than ninety (90) days after the third (3rd) anniversary of the date all Five Towns executed this Renewal License; and Thirty-One Thousand Dollars (\$31,000) will be paid no more than ninety (90) days after the fourth (4th) anniversary of the date all Five Towns executed this Renewal License. The three payments will be allocated among the Five Towns in proportion to that town’s percentage of the total subscriber count of the Five Towns, as of December 31 for the year immediately preceding the year the payment is due, and will be based on subscriber counts provided by the Licensee. The first capital payment due under this Renewal License, in the amount of \$150,000, will be based on the following subscriber count for of December 31, 2023, and will be allocated among the Five Towns based on their percentages of total subscriber count as set forth in the following table:

| TOWN | 2023 SUBSCRIBERS | % OF FIVE TOWN TOTAL | DOLLAR GRANT ALLOCATION |
|------------------|------------------|----------------------|-------------------------|
| GREAT BARRINGTON | 1578 | 27% | \$40,500 |
| LEE | 1504 | 25% | \$37,500 |
| LENOX | 1400 | 24% | \$36,000 |
| STOCKBRIDGE | 729 | 12% | \$18,000 |
| SHEFFIELD | 733 | 12% | \$18,000 |

(b) The \$31,000 capital payment due in Year 3 of this Renewal License will be allocated in similar fashion to the table in Section 5.7 (a) above, but will be calculated using subscriber count totals for the Five Towns provided by Licensee as of December 31, 2026. The \$31,000 capital payment due in Year 4 of this Renewal License will be allocated in similar fashion to the table in section 5.7 (a) above, but will be calculated using subscriber count totals for the Five Towns provided by Licensee as of December 31, 2027. For each instance of re-calculating the percentages of allocation of the capital grants, Licensee shall provide each of the Five Towns with a document certifying the new subscriber count and the re-calculation of grant shares among the Five Towns.

(c) The PEG Access Capital Grant shall be used solely for PEG Access capital costs incurred by the Access Corporation in support of PEG Access programming on the PEG Access Channels carried on the Cable System. Upon written request by the Licensee, and no more than once per year, the Issuing Authority’s designee or the Access Corporation shall provide Licensee with an accounting for the preceding calendar year of any expenditures made with the PEG Access Capital Grant.

(d) In the event that the PEG Access Capital Grant required to be made herein is not tendered on or before the date fixed herein, interest due on such required payment shall accrue at the Prime Rate and be paid to the Access Corporation from the date due.

(e) Consistent with federal law, the PEG Access Capital Grant may, in Licensee’s sole discretion, be passed through and itemized on Subscribers’ bills.

- (f) The PEG Access Capital Grant, to the extent it is actually used for PEG Access capital expenses, shall not be offset from Licensee's five percent (5%) quarterly Franchise fee payments made pursuant to Section 5.6 above.

Section 5.8 METHOD OF PAYMENT

All payments by the Licensee to the Town pursuant to this Renewal License shall be made payable to the Town and deposited with the Town Treasurer.

Section 5.9 RECOMPUTATION

(a) Tender or acceptance of any payment shall not be construed as an accord that the amount paid is correct, nor shall such acceptance of payment be construed as a release of any claim that the Issuing Authority or the Access Corporation may have for additional sums including interest payable under this Article 5.

(b) Not more than once every three (3) years, the Issuing Authority, or its designee, including an independent certified public accountant hired by the Issuing Authority, shall have the right to inspect records necessary to verify Gross Annual Revenues, as defined herein, in order to establish the accuracy of the payments tendered hereunder. If after any such inspection, an additional undisputed payment is owed, such payment shall be paid within thirty (30) days after any recomputation. The interest on such additional payment shall be charged from the original due date at the Prime Rate during the period that such additional amount is owed.

Section 5.10 EQUIPMENT OWNERSHIP

The Issuing Authority may, at its discretion, delegate responsibility to the Access Corporation for the control and management of the PEG Access channels. The Issuing Authority shall notify Licensee of such delegation in writing no later than 30 days after the effective date of said delegation. The Town, or the Access Corporation, shall own all PEG Access equipment purchased with funding pursuant to Section 5.7 supra. The Licensee shall have no obligation to maintain or insure any such PEG Access equipment.

Section 5.11 REMOTE ORIGINATION POINTS

(a) The Licensee shall continue to maintain the equipment at the origination sites listed in Exhibit B necessary to transmit programming signals from these origination sites for carriage on PEG Access channels.

(b) The Licensee shall continue to maintain the connection to its system for each of the origination points at the locations set forth in Exhibit B, in order that programming signals can be transmitted from said origination points for carriage on PEG Access channels. The costs of any new connections or any upgrades required for existing connections shall be paid by the Towns or the Access Corporation, if designated by the Towns.

Section 5.12 PEG ACCESS CHANNELS MAINTENANCE

(a) The Licensee shall monitor the PEG Access Channels for technical quality in accordance with FCC rules and regulations, as set forth in sec. 3.1 (a) and 3.16 (a), above.

(b) The Town or, if so delegated, the Access Corporation shall be responsible for maintaining the picture and audio quality of PEG Access programming delivered to Licensee. The Licensee shall be responsible for maintaining the return infrastructure up to the point of connection for the PEG Access Channel modulators and demodulators, except as otherwise addressed in this Renewal License.

Section 5.13 CONVERSION OF PEG ACCESS CHANNELS TO HIGH DEFINITION

(a) As of the Effective Date, Licensee is transporting the PEG Access Channel programming in standard definition (“SD”) from the origination sites listed in Exhibit B to Licensee’s headend via existing return lines.

(b) On or after the Effective Date, the Issuing Authority, or the Access Corporation, may, upon written request, request that the Licensee replace one, two, or all three of the existing SD PEG Access Channels with PEG Access Channels in a High Definition (“HD”) format. Within one hundred and eighty (180) days of such a request, the Licensee shall distribute the requested PEG Access Channels in HD format to subscribers subject to the following conditions:

- 1) The Issuing Authority or Access Corporation is capable of producing and delivering programming to Licensee in an HD format;
- 2) Licensee may implement HD carriage of the PEG Access Channels in any technological manner it chooses (including selection of compression, utilization of IP, and other processing characteristics); and
- 3) The Issuing Authority or its designated Access Corporation enters into a contract with Licensee’s commercial services group that will govern the terms, conditions, and costs for the one-time equipment upgrades necessary for the conversion to HD, as well as the ongoing transmission, maintenance, and monitoring of such HD PEG Access Channel signal(s) from the origination point(s) on Exhibit B to the Licensee’s headend or hub site. In the event the contract with Licensee’s commercial services group is terminated prior to the expiration of this License, Licensee’s obligation to provide the PEG Access Channel(s) covered by the contract shall also cease.

Section 5.14 CENSORSHIP

Neither the Issuing Authority, the Licensee, nor the Access Corporation shall engage in any program censorship or any other control of the content of PEG Access programming on the Cable System, except as otherwise required or permitted by applicable law.

Section 5.15 ACCESS PROGRAMMING

Except as otherwise set forth in applicable law, editorial discretion and the content of the programming on the Public Access Channel, and any liability therefor, shall reside solely with, and be the sole responsibility, of the Access Corporation.

Section 5.16 THIRD PARTY RIGHTS

The Issuing Authority and the Licensee herein acknowledge and agree that the Access Corporation is not a party to this Renewal License and that any provisions herein that may affect the Access Corporation are not intended to create any rights on behalf of the Access Corporation.

Section 5.17 PEG ACCESS PROGRAMMING COSTS

Except as otherwise provided for in this License and applicable law, there shall be no direct charges to the Town, the Access Corporation, or PEG Access Users by the Licensee for use of the PEG Access facilities required herein, provided, however, that the Licensee may line-item and/or otherwise pass-through such PEG access funding costs to subscribers strictly in compliance with applicable laws and regulations.

ARTICLE 6 - SUBSCRIBER RIGHTS AND CONSUMER PROTECTIONS

Section 6.1 CUSTOMER SERVICE OFFICE

Licensee shall maintain and operate a full-time conveniently located local customer service office, for the return/exchange of Subscriber equipment, and bill payment, at a location as required by FCC customer service standards for the full term of this Renewal License. Said customer service office shall be open for walk-in business during normal business hours. Currently, Licensee maintains such a location in the Town of Lee. In the event that Licensee moves or closes that facility it will give the Town at least 120 day's written notice and will, if requested, meet with representatives of the Towns to discuss and explain its decision to move or close the office.

Section 6.2 CUSTOMER SERVICE STANDARDS

The Licensee shall comply with FCC Customer Service Standards, as amended from time to time, which standards are attached hereto, and made a part hereof, as Exhibit D.

Section 6.3 DEFINITION AND DOCUMENTATION OF CUSTOMER COMPLAINT

Complaint is defined in Article One, Definitions. Licensee shall comply with both FCC and the Department's requirements for defining and documenting a customer complaint. If there is a difference in definition and documentation between the FCC and Department requirements, the Department requirements shall be adhered to.

Section 6.4 COMPLAINT RESOLUTION PROCEDURES

(a) In compliance with applicable law(s), including for example 47 C.F.R. §§ 76.1600, 76.1602, 76.1603, 76.1619, 76.1700, 76.1713., M.G.L. c. 166A, § 10, 207 C.M.R. §§ 10.03, 10.07, the Licensee shall maintain a procedure for resolution of billing, privacy, service, disputes, and all other complaints by subscribers. To the extent required by applicable laws, the Licensee shall provide, on an annual basis, a written description of said procedures, including telephone numbers to call for all complaints and other services, to all subscribers, and the Issuing Authority.

(b) Upon reasonable notice, the Licensee shall expeditiously investigate and resolve all complaints regarding the quality of Service, equipment malfunctions, billing disputes, customer service issues, and similar matters

(c) Upon receipt of a subscriber complaint regarding the quality of Service, equipment malfunctions, and similar matters, referred to Licensee by the CAC, Licensee shall promptly investigate and resolve complaints. Such investigation and resolution shall include direct communication with the subscriber identified by the CAC as well as with the CAC. Licensee's communication with the CAC shall include an explanation of the results of Licensee's investigation and ultimate resolution of the complaint.

Section 6.5 PRIVACY WRITTEN NOTICE

At the time of entering into an agreement to provide any Cable Service to a subscriber, and annually thereafter to all Cable System Subscribers, the Licensee shall provide Subscribers with written notice regarding personally identifiable information and subscriber privacy as required by Section 631(a)(1) of the Cable Act. Pursuant to the Cable Act, and FCC Regulations (see 47 C.F.R. § 76.1600), a weblink to Licensee's updated Privacy Policy is provided annually. Moreover, Licensee's most current privacy policy is available anytime upon request or online. If the conditions for electronic delivery under

47 C.F.R. § 76.1600 are not met, or if a subscriber opts out of electronic delivery, then, pursuant to the requirements of 47 C.F.R. § 76.1600(d), Licensee will deliver written notice by paper copy.

Section 6.6 SUBSCRIBER'S RIGHT TO PRIVACY, INSPECTION AND VERIFICATION OF INFORMATION

Licensee shall comply with all privacy provisions regarding Cable Service as outlined in applicable federal and State laws including, but not limited to, the provisions of Section 631 of the Cable Communications Policy Act of 1984, 47 USC § 551 and Article 6 herein. Licensee's privacy policy outlines how Licensee complies with applicable law as it relates to its privacy obligations to its subscribers, including subscribers' right to inspect and verify information about him/her/or them in Licensee's possession and the nature of personally identifiable information collected or to be collected with respect to the subscriber and the nature of the use of such information, among other things.

Section 6.7 PARENTAL CONTROL CAPABILITY

The Licensee shall provide, upon request and to the extent required by applicable law, Subscribers with the capability to control the reception of any Cable Television System channel being received.

Section 6.8 BILLING AND TERMINATION PROCEDURES

Licensee will comply with the consumer protection regulations of the Department, 207 CMR 10.00 et seq., as in effect at the time as may be amended. See Exhibit E.

Section 6.9 ADVANCE BILLING AND PAYMENT

- (a) Subscribers shall not be billed in advance by more than a one-month period except with the subscriber's consent.
- (b) Licensee shall comply with 207 CMR 10.05, as may be amended, and which currently provides, in part:
 - (1) Subscriber payment to the Licensee is due on the date marked on the bill, which shall be a date certain and in no case a statement that the bill is due upon receipt. The due date shall not be less than five business days following the mailing date of the bill.
 - (2) A Subscriber account shall not be considered delinquent unless payment has not been received by the cable operator at least 30 days after the bill due date.

Section 6.10 EMPLOYEE IDENTIFICATION CARDS

All of Licensee's customer-facing employees, including repair and sales personnel and all contracted or subcontracted personnel, entering private property for the purposes of performing work on Licensee's behalf shall, upon request, be required to show an employee photo identification card bearing a picture of said employee.

Section 6.11. NON-DISCRIMINATION

Licensee shall not discriminate against any person in its solicitation or service on the basis of race, color, creed, religion, ancestry, national origin, gender, sexual preference, disability, age, marital

status, or status with regard to public assistance. Licensee shall be subject to all other requirements of Federal and State regulations concerning non-discrimination.

Section 6.12 INSIDE WIRING

Licensee shall abide by all applicable laws and regulations with respect to inside wiring.

Section 6.13 VOLUNTARY DISCONNECTION OF SERVICE

For Subscribers who request full disconnection of Cable Service, subject to applicable law, Licensee shall comply with 207 CMR 10.06(2), as amended.

Section 6.14 ELECTRONIC NOTICE

Any bill, notice or other communication provided or issued by Licensee to any subscriber may be provided or issued, if such subscriber so consents, solely by electronic means.

ARTICLE 7 - ADMINISTRATION, REGULATION, AND LICENSEE'S PERFORMANCE

Section 7.1 REGULATORY AUTHORITY

The Issuing Authority or their designee(s) shall be responsible for the day-to-day regulation of the Cable Television System. The Department shall monitor and enforce the Licensee's compliance with the terms and conditions of this Renewal License. The Issuing Authority shall notify the Licensee in writing of any instance of non-compliance pursuant to Section 7.7 infra.

Section 7.2 INDEMNIFICATION

The Licensee shall, at its sole cost and expense, indemnify, defend, and hold the Issuing Authority, the Town and its officials, boards, commissions, employees, or agents, harmless at all times during the term of this Renewal License from claims for damage due to the negligence or willful misconduct of Licensee, its employees, officers, or agents, and contractors in the construction, installation, operation, maintenance, and/or removal of the Cable Television System under the Renewal License, including without limitation, damage to Persons or property, both real and personal, caused by the construction, installation, operation, and removal of any structure, equipment, wire, or cable installed. Indemnified expenses shall include any judgment, cost, interest, and attorney's fees and costs up to such time that the Licensee assumes defense of any action hereunder. The extent of this indemnification shall not be limited by any obligation or any term or condition of any insurance policy. The Issuing Authority shall give the Licensee prompt written notice of its obligation to indemnify and defend any Indemnified Party pursuant to this Section, sufficient to avoid the entry of a default judgment against Licensee. Licensee shall not be required to provide indemnity under this Section 7.2 to the extent that the claim results from unlawful acts, willful misconduct, or negligence on the part of the Issuing Authority, Town, or any official, board, commission, employee, or agent thereof.

Section 7.3 INSURANCE

(a) At all times during the term of this Renewal License, including the time for removal of facilities provided for herein, the Licensee shall obtain, pay all premiums for and, if requested in writing, file, with the Issuing Authority, insurance company certificates of the following insurance:

| | |
|---|--|
| Workers' Compensation | Statutory Limits |
| Commercial General Liability | \$2,000,000 per occurrence, \$4,000,000 General Aggregate |
| Auto Liability including coverage on all owned, non-owned hired autos | \$1,000,000 per occurrence Combined Single Limit |
| Umbrella Liability | \$5,000,000 per occurrence |

(b) The commercial general liability insurance identified above shall name the Town, its officers, boards, commissions, committees, agents and employees as additional co-insureds on all claims on account of injury to or death of a person or persons, occasioned by the construction, installation, maintenance or operation of the Cable System, or alleged to have been so occasioned. The commercial general liability insurance identified above shall also name the Town, its officers, boards, commissions, committees, agents, and employees as additional co-insureds on all claims of property damage, real or personal, occasioned or alleged to have been so occasioned by the construction, installation, maintenance or operation of the Cable System.

(c) The following conditions shall apply to the insurance policies required herein: (i) Such insurance shall commence no later than the Execution Date of this Renewal License; (ii) Such insurance shall be primary with respect to any insurance maintained by the Town and shall not call on the Town's insurance for contributions; (iii) Such insurance shall be obtained from brokers or carrier authorized to transact insurance business in the State; and (iv) the Licensee's failure to obtain, to procure, or to maintain the required insurance shall constitute a material breach of this Renewal License.

Section 7.4 PERFORMANCE BOND

(a) The Licensee shall maintain at its own cost and expense throughout the term of this Renewal License a faithful performance bond running to all of the Five Towns, with at least one good and sufficient surety licensed to do business in the State in the sum of One Hundred Thousand Dollars (\$100,000). This Performance Bond shall be maintained for the benefit of all of the Five Towns. Said bond shall be conditioned upon the faithful performance and discharge of all material obligations imposed by this Renewal License.

(b) The performance bond shall be effective throughout the term of the Renewal License, including the time for removal of all of the facilities provided for herein, and shall be conditioned that in the event that Licensee shall fail to comply with any one or more material term or condition of the Renewal License, or to comply with any lawful order, permit, direction of any department, agency, commission, committee, board, division or office of the Town having jurisdiction over Licensee's acts, or to pay any claims, liens or taxes due the Town which arise by reason of the construction, upgrade, maintenance, operation, and/or removal of the Cable Television System, the Town shall recover from the surety of such bond all damages suffered by the Town as a result therefor, pursuant to the provisions of Section 7.7 and 7.8 infra.

(c) Said bond shall be a continuing obligation of the Renewal License, and thereafter until the Licensee has satisfied all of its obligations to the Town that may have arisen from the grant of this

Renewal License or from the exercise of any privilege therein granted. In the event that the Town recovers from said surety, the Licensee shall take immediate steps to reinstate the performance bond to the appropriate amount required herein. Neither this Section, any bond accepted pursuant hereto, nor any damages recovered thereunder, shall limit the liability of Licensee under this Renewal License.

Section 7.5 NOTICE OF CANCELLATION OR REDUCTION OF COVERAGE

The insurance policies required herein shall each contain an explicit endorsement stating that such insurance policies are intended to cover to liability assumed by the Licensee under the terms of the Renewal Licensee and shall contain the following endorsement:

“It is hereby understood and agreed that this policy shall not be cancelled until thirty (30) days after receipt by the Issuing Authority of one (1) copy of a written notice of such intent to cancel the coverage required herein.”

Provision of the foregoing notice shall not excuse Licensee from compliance with Section 7.3 above.

Section 7.6 REPORTING

Upon written request of the Issuing Authority, the Licensee shall submit to the Issuing Authority, or their designee(s), copies of: (i) all certificates of insurance for policies as required herein; and (ii) the performance bond as required herein.

Section 7.7 DETERMINATION OF BREACH

In the event that the Issuing Authority has reason to believe that the Licensee has defaulted in the performance of any or several material provisions of this Renewal License, except as excused by Force Majeure, the Issuing Authority shall first informally discuss the matter with the Licensee. If these discussions do not lead to resolution of the alleged problem, the Issuing Authority shall notify the Licensee in writing, by certified mail, of the exact nature of the alleged default or noncompliance, including the details relating thereto. The Licensee shall either:

(a) Within thirty (30) days from receipt of such notice, respond to the Issuing Authority in writing, contesting the Issuing Authority’s assertion of default and provide such information or documentation as may be necessary to support the Licensee’s position; or

(b) Within sixty (60) days from receipt of such notice, cure any such default (and provide written evidence of the same), or, in the event that by nature of the default, such default cannot be cured within such sixty (60) day period, to take reasonable steps to cure said default and diligently continue such efforts until said default is cured. The Licensee shall communicate with the Issuing Authority as to the Licensee’s efforts during such cure period as a minimum, at least every thirty (30) days until such cure efforts are completed.

(c) In the event that the Licensee fails to respond to such notice of default or to cure the default or to take reasonable steps to cure the default within the required sixty (60) day period, the Issuing Authority shall promptly schedule a public hearing to be conducted by the Issuing Authority no sooner than fourteen (14) days after written notice, by certified mail, to the Licensee. The Licensee shall be provided with the opportunity to offer evidence and test the Issuing Authority’s evidence, including by

presenting witness testimony and cross-examining any opposing witnesses, and generally to be heard at such public hearing. Any such hearing may be transcribed at Licensee's expense, and any evidence presented therein shall be made part of the public record, subject to claims of confidentiality asserted by Licensee. Within thirty (30) days after close of said public hearing, the Issuing Authority shall determine whether or not the Licensee is in default of any material provision of the Renewal License. In the event the Issuing Authority, after such hearings, determines that the Licensee is in such default, the Issuing Authority may determine to pursue any of the following remedies:

- (i) assess liquidated damages in accordance with the schedule set forth in Section 7.8 below;
- (ii) seek specific performance of any provision in the Renewal License which reasonably lends itself to such remedy as an alternative to recovery of monetary damages;
- (iii) commence an action at law for recovery of monetary damages;
- (iv) foreclose on all or any appropriate part of the security provided pursuant to Section 7.4 herein;
- (v) declare the Renewal License to be revoked subject to Section 7.18 below and applicable law; and/or
- (vi) invoke any other lawful remedy available to the Town.

Section 7.8 LIQUIDATED DAMAGES

(a) Because Licensee's failure to comply with material terms of this Agreement may result in harm to the Town, and because it will be difficult to measure the extent of such injury, the Town may assess liquidated damages against Licensee in the amount set forth in Section 7.9 per day for each day the violation continues, provided Licensee has had notice and an opportunity to cure in accordance with Section 7.7 and the Town is not pursuing other penalties or remedies. The Town shall provide Licensee with written notice that it intends to assess liquidated damages as a remedy. Such damages shall be an exclusive remedy for the time period in which they are assessed, provided, however, they shall not be a substitute for specific performance by Licensee or legal action by the Town once assessment of liquidated damages ceases, but shall be in addition to such specific performance or legal action. Nothing herein is intended to allow duplicative recovery from or payments by Licensee or its surety.

(b) The first day for which liquidated damages may be assessed, if there has been no cure after the end of the applicable cure period, shall be the date after the end of the applicable cure period, including any extension of the cure period granted by the Town. Liquidated damages may not be assessed for a time period exceeding fifty (50) days. The Town may commence revocation proceedings and/or initiate an action in law or equity in a court of competent jurisdiction after the assessment of liquidated damages or in lieu of liquidated damages.

(c) The amount of all liquidated damages per year shall not exceed twenty-five thousand dollars (\$25,000) in the aggregate between and among the Five Towns. With respect to liquidated damages, all violations or failures arising from the same factual events, even though they may affect multiple Subscribers, shall be assessed as a single violation, and a particular violation or failure may only be assessed under any one material breach term set forth in Section 7.9.

Section 7.9 MATERIAL BREACH

The following violations by Licensee of this Renewal License constitute a material breach of a material term or condition of this agreement subject to liquidated damages under Section 7.7 in the amounts set forth below:

- (a) Transfer of the License without complying with the requirements of Section 2.5 above – liquidated damages of \$100 per day.
- (b) Repeated or persistent failure to provide Cable Service as specified in Sections 3.1, 3.2, 3.4, 4.1, 4.6, and 4.7 – liquidated damages of \$50 per day.
- (c) Failure to comply with the EAS requirements set forth in Section 3.5 – liquidated damages of \$100 per day.
- (d) Repeated or persistent failure to comply with the system construction and maintenance requirements set forth in Sections 3.9, 3.11, 3.12, and 3.16 – liquidated damages of \$50 per day.
- (e) Repeated or persistent failure to comply with the PEG requirements set forth in Sections 5.1, 5.2, 5.3, 5.4, 5.5, 5.11, 5.12 – liquidated damages of \$100 per day.
- (f) Repeated or persistent failure to pay fees pursuant to Sections 5.6 and 5.7 – liquidated damages of \$100 per day.
- (g) Repeated or persistent failure to comply with the insurance and bond requirements of Sections 7.3 and 7.4 – liquidated damages of \$100 per day.
- (h) Repeated or persistent violation of Subscriber privacy requirements pursuant to 47 U.S.C. § 551 – liquidated damages of \$50 per day.
- (i) Repeated or persistent failure to comply with the requirements of Section 6.4 (“Complaint Resolution Procedures”) and/or the standards set forth in Exhibits D & E (the Federal and Commonwealth Customer Service Standards) – liquidated damages of \$50 per day.

Section 7.10 NO WAIVER – CUMULATIVE REMEDIES

(a) Subject to 47 U.S.C. sec. 546 (d), no failure on the part of the Issuing Authority, or the Licensee to exercise, and no delay in exercising, any right in this Renewal License shall operate as a waiver thereof, nor shall any single or partial exercise of any such right preclude any other right, all subject to the conditions and limitations contained in this Renewal License.

(b) The rights and remedies provided herein are cumulative and not exclusive of any remedies provide by law, and nothing contained in this Renewal License shall impair any of the rights of the Issuing Authority or the Licensee under applicable law, subject in each case to the terms and conditions of this Renewal License.

(c) A waiver of any right or remedy by the Issuing Authority or the Licensee at any one time shall not affect the exercise of such right or remedy, or any other right or remedy, by the Issuing Authority or the Licensee at any other time. In order for any waiver by the Issuing Authority or the Licensee to be effective, it shall be in writing.

(d) The failure of the Issuing Authority or the Licensee to take any action in the event of any breach by the Licensee or the Issuing Authority shall not be deemed or construed to constitute a waiver of or otherwise affect the right of the Issuing Authority or the Licensee to take any action permitted by this Renewal License at any other time in the event that such breach has not been cured, or with respect to any other breach by the Licensee or the Issuing Authority.

Section 7.11 PERFORMANCE EVALUATION HEARING

(a) The Issuing Authority may, at its discretion, but no more frequently than annually hold a performance evaluation hearing as it may from time to time deem necessary. Any such hearing shall be open to the public and properly noticed. The purpose of said performance evaluation hearing shall be to review Licensee's compliance with the material terms and conditions of this Renewal License. The Issuing Authority shall have the right to question Licensee concerning the operation, maintenance, and extension of the Cable Television System and any other matters regulated by this Renewal License, including, but not limited to, customer service, complaint response, programming and PEG Access channels, facilities, and support.

(b) For a hearing provided for under this section, the Licensee shall be given twenty-one (21) days prior written notice of any and all topics to be discussed as well as the date, time, and place of such any performance evaluation hearing. During such review and evaluation by the Issuing Authority, Licensee shall fully cooperate with the Issuing Authority or its designee and produce such documents or other materials as are reasonably requested by the Issuing Authority and reasonably related to material compliance with the Renewal License. The Issuing Authority shall arrange for announcement of each evaluation hearing on a PEG Access channel. One or more of the Issuing Authorities may elect to hold a joint performance evaluation hearing with the Licensee. Any such hearing may be in person or held remotely.

(c) Within thirty (30) days after the conclusion of any such evaluation hearing, the Issuing Authority(ies) shall issue a written report with respect to the adequacy of Cable System performance, quality of service, and any other matter discussed during the evaluation hearing, and send one (1) copy to the Licensee and file one (1) with the Town Clerk Office(s). If inadequacies are found which result in a violation of any of the material provisions of the Renewal License, the Licensee shall respond in writing within thirty (30) days and propose a plan for implementing any changes or improvements necessary.

Section 7.12 CABLE ADVISORY COMMITTEE ("CAC")

(a) At the discretion of the Issuing Authority and as provided for in this Renewal License, the CAC may be vested by the Issuing Authority with such power and authority as may lawfully be delegated, including participation in the CAC with the Lee, Lenox, Sheffield, and Stockbridge. However, only the Issuing Authority may grant and sign a Renewal License; agree to amend a Renewal License; grant or deny consent to a transfer of a Renewal License; find the Licensee in breach of the Renewal License; or revoke the Renewal License.

(b) The Licensee shall meet with the Issuing Authority or CAC on a quarterly basis to review the Licensee's compliance with the material terms of the Renewal License. Such meetings may be requested by the Issuing Authority and the CAC; the Licensee's or designee(s) shall make every effort to attend each such meeting, either remotely or in person.

Section 7.13 INFORMATION REQUESTS AND RIGHT TO INSPECT RECORDS AND FACILITIES

(a) Upon written request of the Issuing Authority, the Licensee shall promptly, and no later than within thirty (30) calendar days, submit written information with respect to the Cable System regarding the Licensee, as may be reasonably required to establish the Licensee's compliance with its material obligations pursuant to this License.

(b) If the Licensee believes that any documentation requested by the Issuing Authority pursuant to this Renewal License involves proprietary or confidential information, then the Licensee need not disclose the information to the Town; however, the Licensee shall confer with the Town Counsel, with the Issuing Authority's permission, to explain the basis of the Licensee's claim of a proprietary interest and attempt to implement a mutually acceptable method of confidential treatment of such records such

that they shall not become public records, or to otherwise provide information sufficient that is not considered confidential or proprietary that the Issuing Authority agrees will satisfy its request .

(c) Upon reasonable written notice, the Issuing Authority may visit the place(s) of business and other premises and examine the records and facilities of the Licensee during normal business hours to determine Licensee's compliance with the material provisions of this Renewal License.

Section 7.14 QUALITY OF SERVICE

Where there exists evidence which, in the reasonable judgement of the Issuing Authority, casts doubt upon the reliability or technical quality of Cable Service(s), the Issuing Authority shall have the right and authority to require Licensee to request data and information provided by Licensee to the FCC demonstrating compliance with FCC signal quality requirements.

Section 7.15 FINANCIAL, COMPLAINT, AND OTHER REPORTS

(a) The Licensee shall furnish the Issuing Authority, or its designee(s), no later than one hundred twenty (120) days after the end of Licensee's Fiscal Year, Department Forms 200 and 400, prepared in accordance with the Department's rules and regulations.

(b) The Licensee shall furnish the Issuing Authority, or its designee(s), no later than one hundred twenty (120) days after the end of the Licensee's Fiscal Year, a statement of its Gross Annual Revenues, upon which its License Fee is based.

(c) The Licensee shall submit a completed copy of the Department's Form 500 to the Issuing Authority, or its designee(s), as required by the Department.

(d) The Licensee shall file a written report containing the number of Subscribers in the Town with the Issuing Authority, or its designee(s), and said report shall be filed annually with the Financial Reports required herein.

Section 7.16 NON-EXCLUSIVITY OF REMEDY

No decision by the Issuing Authority or the Town to invoke any remedy under this Renewal License or under any statute, law, or ordinance shall preclude the availability of any other such remedy.

Section 7.17 DUAL FILINGS

If requested in writing, the Licensee shall make available to the Town, at the Licensee's expense, copies of any specifically identified petitions or communications filed by the Licensee with any State or federal agency or commission pertaining to any material aspect of this License.

Section 7.18 TERMINATION

The termination of this Renewal License and the Licensee's rights herein shall become effective upon the earliest to occur of: (i) the revocation of the Renewal License by action of the Issuing Authority, pursuant to Section 7.7 and exhaustion of all appeals; (ii) the abandonment of the Cable System, in whole or material part, by the Licensee without the express, prior approval of the Issuing Authority; or (iii) the expiration of the term of this Renewal License and non-renewal in accordance with the provisions of the Cable Act. In the event of any termination, the Town shall have all of the rights provided in the Renewal License.

ARTICLE 8 - GENERAL PROVISIONS

Section 8.1 ENTIRE AGREEMENT

This instrument contains the entire agreement between the parties, supersedes all prior agreements or proposals except as specifically incorporated herein, and cannot be changed orally but only by instrument in writing executed by the parties.

Section 8.2 CAPTIONS

The captions to sections throughout this Renewal License are intended solely to facilitate reading and reference to the sections and provisions of the Renewal License. Such captions shall not affect the meaning or interpretation of this Renewal License.

Section 8.3 SEVERABILITY

If any section, sentence, paragraph, term, or provision of this Renewal License is determined to be illegal, invalid, or unconstitutional, by any court of competent jurisdiction or by any State or federal regulatory agency having jurisdiction thereof, such determination shall have no effect on the validity of any other section, sentence, paragraph, term, or provision thereof, all of which shall remain in full force and effect for the term of this Renewal License.

Section 8.4 FORCE MAJEURE

If for any reason of force majeure either party is unable in whole or in part to carry out its obligations hereunder, said party shall not be deemed in violation or default during the continuance of such inability. Unless further limited elsewhere in this renewal License, the term "force majeure" as used herein shall have the following meaning: strikes; acts of God; acts of public enemies, orders of any kind of the government of the United States of America or of the Commonwealth of Massachusetts or any of their departments, agencies, political subdivisions, or officials, or any civil or military authority; insurrections; riots, epidemics; declared public health emergencies; landslides; lightning; earthquakes; fires, hurricanes; volcanic activity; storms; floods; washouts; droughts; arrests; civil disturbances; explosions; partial or entire failure of utilities; unavailability of materials such as fiber, or any other cause or event not reasonably within the control of the Licensee or Issuing Authority.

Section 8.5 RENEWAL LICENSE EXHIBITS

The Exhibits to this Renewal License, attached hereto, and all portions thereof, are incorporated herein by reference and expressly made a part of this Renewal License.

Section 8.6 WARRANTIES

The Licensee warrants, represents, and acknowledges that, as of the Execution date of this Renewal License:

- (a) The Licensee is duly organized, validly existing and in good standing under the laws of the State of Delaware and is authorized to do business in Massachusetts;
- (b) The Licensee has the requisite power and authority under applicable law and its bylaws and articles of incorporation and/or other organizational documents, is authorized by resolutions of its Board of Directors or other governing body, and has secured all consents required to be obtained as of the Execution Date of this Renewal License, to enter into and legally bind the Licensee to this Renewal License and to take all actions necessary to perform all of its obligations pursuant to this Renewal License;

(c) This Renewal License is enforceable against the Licensee in accordance with the provisions herein, subject to applicable State and federal law;

(d) There is no action or proceeding pending or threatened against the Licensee which would interfere with its performance of this Renewal License; and

(e) Pursuant to 47 U.S.C. sec. 545 (f), as of the Effective Date, the performance of all terms and conditions of this Renewal License is commercially practicable.

Section 8.7 APPLICABILITY OF RENEWAL LICENSE

All of the provisions in this Renewal License shall apply to the Town, the Licensee, and their respective successors and assignees.

Section 8.8 JURISDICTION

Jurisdiction and venue over any dispute or judgment rendered pursuant to any Article herein shall be in a federal or state court or agency of appropriate venue and subject matter jurisdiction located in the Commonwealth of Massachusetts and the parties by this License subject themselves to the personal jurisdiction of said court or agency for the entry of any such judgment and for the resolution of any dispute, action, or suit arising in connection with the entry of such judgment.

Section 8.9 NOTICE

Every notice to be served under this Renewal License shall be delivered by hand, sent by certified mail (postage prepaid), or overnight delivery service, and shall be deemed to have been given on the date of hand delivery or on the mailing date thereof. The Parties may also send a required notice by electronic mail, as a supplement to, but not instead of, the delivery options set forth in the prior sentence. Notices shall be addressed as follows:

(a) To the Issuing Authority:

Town of Great Barrington Select Board
Great Barrington Town Hall
334 Main Street
Great Barrington, MA 01230
(C/O Mark Pruhenski, Town Manager
Mpruhenski@townofgb.org)

Or such other address as the Issuing Authority may specify in writing to the Licensee.

b) To the Licensee:

Spectrum Northeast, LLC
301 Barber Avenue
Worcester, MA 01606
ATTN: Director, Government Affairs

With a copy to:

Charter Communications, Inc.
601 Massachusetts Ave. NW
Suite 400W

Washington, DC, 20001

ATTN: Vice President, Local Government Affairs & Franchising

Email: paul.abbott@charter.com.

Or such other address as the Licensee may specify in writing to the Issuing Authority.

It shall be the responsibility of each Party to ensure that its mailing address and e-mail address are up to date and accurate. Accordingly, to the extent the mailing address or e-mail address for either Party changes during the term of this Renewal License Agreement, that Party shall provide written notice to the other Party within sixty (60) days of such a change. For the purpose of providing a new address, the Parties agree that notice by electronic mail shall suffice.

Section 8.10 TOWN'S RIGHT OF INTERVENTION

The Town hereby reserves to itself, and the Licensee acknowledges the Town's right, to the extent authorized by applicable law or regulation, to intervene in any suit, action or proceeding involving this Renewal License, or any provision in this Renewal License.

Section 8.11 RESERVATION OF RIGHTS

Acceptance of the terms and conditions of this Renewal License Agreement will not constitute, nor be deemed to constitute, a waiver, either expressly or impliedly, by Licensee or by the Issuing Authority of any constitutional or legal right, which either party may have or may be subsequently determined to have, either by subsequent legislation or court decisions. The Issuing Authority and Licensee acknowledge that each reserve all of their respective rights under applicable Federal and Commonwealth Constitutions and laws.

Section 8.12 INCORPORATION of M.G.L. c. 166A, § 5

The provisions of M.G.L. c. 166A, § 5(a)-(o), as they presently exist and as they may from time to time in the future be amended, are incorporated into this Renewal License, and shall be governing on all parties. The parties agree that the rights and obligations established in this Renewal License comply with the present form of M.G.L. c. 166A, § 5(a)-(o).

Section 8.13 NO THIRD-PARTY BENEFICIARIES

This License is not intended to create any rights or benefits on behalf of any Person other than the parties to this Renewal License.

Section 8.14 LIMITATION OF ISSUING AUTHORITY LIABILITY

In accordance with 47 U.S.C. sec. 555a (a), in any court proceeding involving any claim against the Issuing Authority or other governmental entity, or any official, member, employee, or agent of the Issuing Authority or other governmental entity, arising out of the regulation of cable service or from a decision of approval or disapproval with respect to a grant, transfer, or amendment of this License, any relief, to the extent such relief is required by any provision of Federal, State, or local law, shall be limited to injunctive and declaratory relief.

WITNESS OUR HANDS AND OFFICIAL SEALS:

Select Board:

For Spectrum Northeast, LLC:

Date: _____

Date: _____

EXHIBITS

EXHIBIT A: TOWN SERVICE AREA OR STRAND MAP

EXHIBIT B: PUBLIC BUILDINGS TO BE PROVIDED CABLE SERVICE, LOCAL ORIGINATION SITES

EXHIBIT C: CALCULATION OF QUARTERLY LICENSE FEE PAYMENT QUARTERLY REPORT

EXHIBIT D: FCC CUSTOMER SERVICE OBLIGATIONS

EXHIBIT E: 207 CMR 10.00: BILLING AND TERMINATION OF CABLE SERVICE

EXHIBIT A: TOWN SERVICE AREA OR STRAND MAP

Map follows this page.

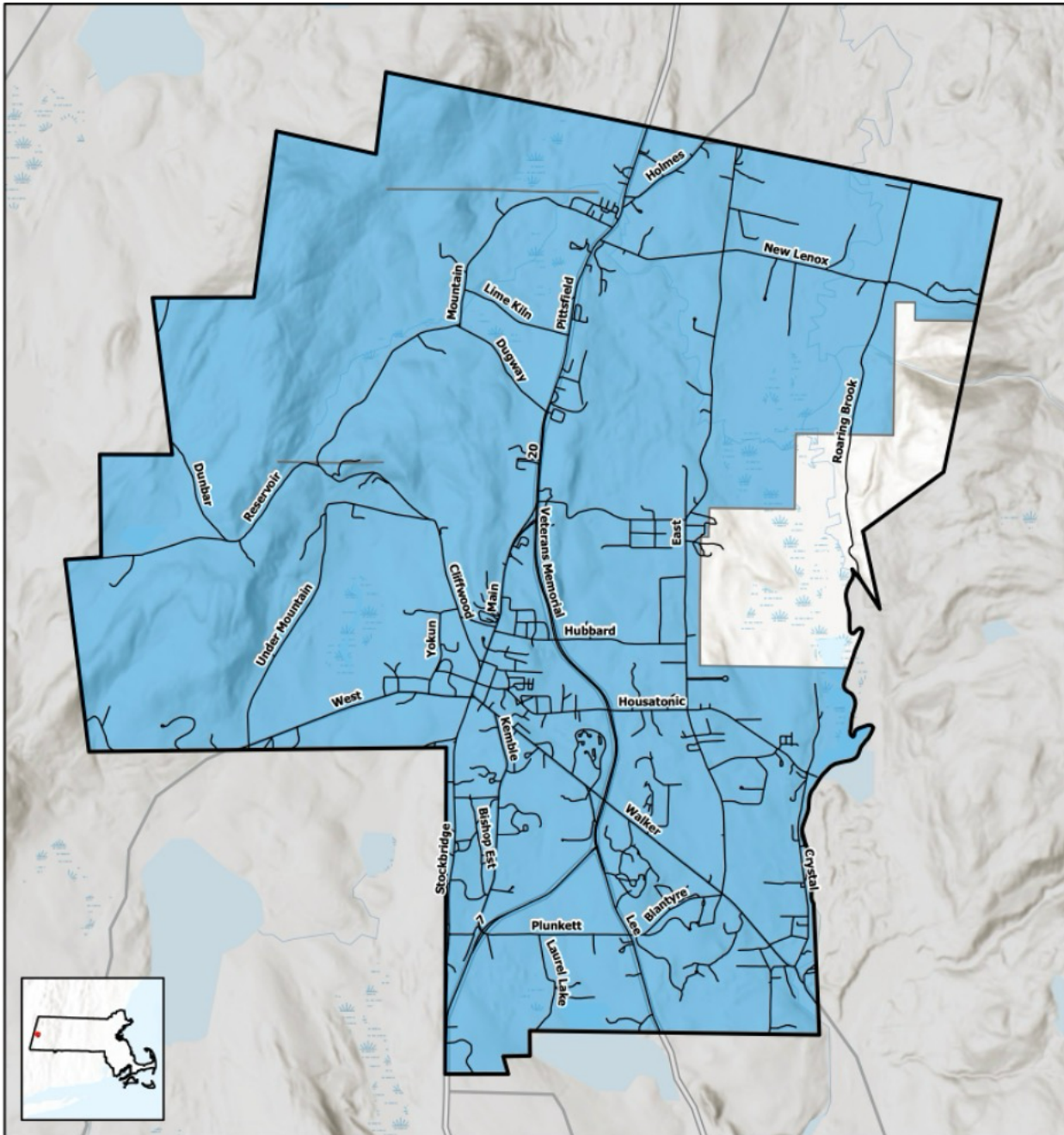

Charter Outside Plant Footprint Lenox, Massachusetts



- Lenox Town Boundary
- Charter Service Areas
- Roads

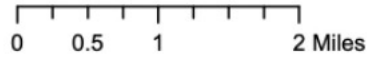

**EXHIBIT B: TOWN OF GREAT BARRINGTON PUBLIC BUILDINGS TO BE PROVIDED CABLE SERVICE,
LOCAL ORINATION SITES**

Pursuant to Section 4.4 herein, the following public buildings and schools shall receive, upon request, Standard Installation and one Cable Service drop, outlet, and monthly Basic Cable Service:

Monument Mountain Regional High School
600 Stockbridge Road
Great Barrington, MA 01230

Great Barrington Fire Department
20 Castle St.
Great Barrington, MA 01230

Great Barrington Police Department
465 Main St.
Great Barrington, MA 01230

Housatonic Fire Station
172 Front St.
Housatonic, MA 01236

Mason Library
231 Main St.
Great Barrington, MA 01230

Ramsdell Public Library
1087 Main Street
Housatonic, MA 01236

The following are the local origination sites subject to Section 5.11 of the License:

Great Barrington Town Hall
334 Main St.
Great Barrington, MA 01230
(existing fiber connection)

EXHIBIT C: CALCULATION OF QUARTERLY LICENSE FEE PAYMENT REPORT

CALCULATION OF QUARTERLY LICENSE FEE PAYMENT

for ____ Quarter 20 ____

License Fee Rate: 5%

| | MONTH of | MONTH of | MONTH of |
|------------------------------|-------------|-------------|-------------|
| Basic Cable Service | | | |
| Expanded Service Tier(s) | | | |
| Pay Programming | | | |
| Additional Outlets | | | |
| Converter Revenues | | | |
| Installations | | | |
| Collection Charges | | | |
| Late Charges | | | |
| Commercial (monthly) | | | |
| Other (specify) | | | |
| Pay-Per-View | | | |
| Bulk Revenue | | | |
| Advertising Revenues | | | |
| Home Shopping Revenues | | | |
| License Fee Revenue | | | |
| Other Revenues | | | |
| Revenue Adjustment (specify) | | | |
| Bad Debt | | | |

Total License Fee before any Adjustment: \$

Adjustment (overpayment) underpayment: \$

License Fee for Quarter: \$

EXHIBIT D: FCC CUSTOMER SERVICE OBLIGATIONS

§ 76.309 Customer service obligations.

(a) A cable franchise authority may enforce the customer service standards set forth in paragraph (c) of this section against cable operators. The franchise authority must provide affected cable operators ninety (90) days written notice of its intent to enforce the standards.

(b) Nothing in this rule should be construed to prevent or prohibit:

(1) A franchising authority and a cable operator from agreeing to customer service requirements that exceed the standards set forth in paragraph (c) of this section;

(2) A franchising authority from enforcing, through the end of the franchise term, pre-existing customer service requirements that exceed the standards set forth in paragraph (c) of this section and are contained in current franchise agreements;

(3) Any State or any franchising authority from enacting or enforcing any consumer protection law, to the extent not specifically preempted herein; or

(4) The establishment or enforcement of any State or municipal law or regulation concerning customer service that imposes customer service requirements that exceed, or address matters not addressed by the standards set forth in paragraph (c) of this section.

(c) Cable operators are subject to the following customer service standards:

(1) Cable system office hours and telephone availability -

(i) The cable operator will maintain a local, toll-free or collect call telephone access line which will be available to its subscribers 24 hours a day, seven days a week.

(A) Trained company representatives will be available to respond to customer telephone inquiries during normal business hours.

(B) After normal business hours, the access line may be answered by a service or an automated response system, including an answering machine. Inquiries received after normal business hours must be responded to by a trained company representative on the next business day.

(ii) Under normal operating conditions, telephone answer time by a customer representative, including wait time, shall not exceed thirty (30) seconds when the connection is made. If the call needs to be transferred, transfer time shall not exceed thirty (30) seconds. These standards shall be met no less than ninety (90) percent of the time under normal operating conditions, measured on a quarterly basis.

(iii) The operator will not be required to acquire equipment or perform surveys to measure compliance with the telephone answering standards above unless an historical record of complaints indicates a clear failure to comply.

(iv) Under normal operating conditions, the customer will receive a busy signal less than three (3) percent of the time.

(v) Customer service center and bill payment locations will be open at least during normal business hours and will be conveniently located.

(2) Installations, outages, and service calls. Under normal operating conditions, each of the following four standards will be met no less than ninety-five (95) percent of the time measured on a quarterly basis:

(i) Standard installations will be performed within seven (7) business days after an order has been placed. "Standard" installations are those that are located up to 125 feet from the existing distribution system.

(ii) Excluding conditions beyond the control of the operator, the cable operator will begin working on "service interruptions" promptly and in no event later than 24 hours after the interruption becomes known. The cable operator must begin actions to correct other service problems the next business day after notification of the service problem.

(iii) The "appointment window" alternatives for installations, service calls, and other installation activities will be either a specific time or, at maximum, a four-hour time block during normal business hours. (The operator may schedule service calls and other installation activities outside of normal business hours for the express convenience of the customer.)

(iv) An operator may not cancel an appointment with a customer after the close of business on the business day prior to the scheduled appointment.

(v) If a cable operator representative is running late for an appointment with a customer and will not be able to keep the appointment as scheduled, the customer will be contacted. The appointment will be rescheduled, as necessary, at a time which is convenient for the customer.

(3) Communications between cable operators and cable subscribers -

(i) Refunds - Refund checks will be issued promptly, but no later than either -

(A) The customer's next billing cycle following resolution of the request or thirty (30) days, whichever is earlier, or

(B) The return of the equipment supplied by the cable operator if service is terminated.

(ii) Credits - Credits for service will be issued no later than the customer's next billing cycle following the determination that a credit is warranted.

(4) Definitions -

(i) **Normal business hours** - The term "normal business hours" means those hours during which most similar businesses in the community are open to serve customers. In all cases, "normal business hours" must include some evening hours at least one night per week and/or some weekend hours.

(ii) **Normal operating conditions** - The term "normal operating conditions" means those service conditions which are within the control of the cable operator. Those conditions which are *not* within the control of the cable operator include, but are not limited to, natural disasters, civil disturbances, power outages, telephone network outages, and severe or unusual weather conditions. Those conditions which *are* ordinarily within the control of the cable operator include, but are not limited to, special promotions, pay-per-view events, rate increases, regular peak or seasonal demand periods, and maintenance or upgrade of the cable system.

(iii) **Service interruption** - The term "service interruption" means the loss of picture or sound on one or more cable channels.

NOTE TO § 76.309:

Section 76.1602 contains notification requirements for cable operators with regard to operator obligations to subscribers and general information to be provided to customers regarding service. Section 76.1603 contains subscriber notification requirements governing rate and service changes. Section 76.1619 contains notification requirements for cable operators with regard to subscriber bill information and operator response procedures pertaining to bill disputes.

[58 FR 21109, Apr. 19, 1993, as amended at 61 FR 18977, Apr. 30, 1996; 65 FR 53615, Sept. 5, 2000; 67 FR 1650, Jan. 14, 2002; 83 FR 7627, Feb. 22, 2018]

Exhibit E: 207 CMR 10.00: BILLING AND TERMINATION OF CABLE SERVICE

REGULATORY AUTHORITY: 207 CMR 10.00: 47 U.S.C. § 552, M.G.L. c. 166A, §§ 2A, 3, 5(1), 10, 16, and 17.

Section:

10.01: Billing Practices Notice

10.02: Services, Rates and Charges Notice

10.03: Form of Bill

10.04: Advance Billing and Issuance of Bill

10.05: Billing Due Dates, Delinquency, Late Charges and Termination of Service

10.06: Charges for Disconnection or Downgrading of Service

10.07: Billing Disputes

10.08: Security Deposits

10.01: Billing Practices Notice

(1) Upon request, a cable television operator shall give written notice of its billing practices to potential subscribers before a subscription agreement is reached. Otherwise, a cable television operator shall give written notice of its billing practices to potential subscribers at the time a subscription agreement is reached. Such notice shall include practices relating to the frequency and timing of bills, payment requirements necessary to avoid account delinquency, billing dispute resolution procedures, and late payment penalties.

(2) A copy of the cable television operator's billing practices notice, work order, and sample subscriber bill shall be filed by March 15th of each year with the Department, the issuing authority, and the operator's local office, where they shall be available for public inspection. If an operator amends its billing practices notice, work order, or subscriber bill after submitting the annual filing, it shall file copies of the amendments with the Department, the issuing authority, and the operator's local office.

(3) At least 30 days prior to implementing a change of one of its billing practices, the cable television operator shall notify in writing the Department, the issuing authority, and all affected subscribers of the change and shall include in the notice a description of the changed practice.

(4) Statements about billing practices in work orders, marketing, materials, and other documents shall be consistent with the billing practices notice.

10.02: Services, Rates and Charges Notice

(1) Upon request, a cable television operator shall give notice of its services, rates, and charges to potential subscribers before a subscription agreement is reached. Otherwise, a cable television operator shall give notice of its services, rates, and charges to subscribers at the time a subscription agreement is reached.

(2) At least 30 days prior to implementing an increase in one of its rates, charges, or fees, or a substantial change in the number or type of programming services, the cable

operator shall notify, in writing, the Department, the issuing authority, and all affected subscribers of the change and shall include a description of the increased rate or charge. The notice shall list the old and new rate or charge and, if applicable, the old and new programming services provided. Notwithstanding the foregoing, a cable television operator shall not be required to provide prior notice of any rate change that is the result of a regulatory fee, franchise fee, or any other fee, tax, assessment, or charge of any kind imposed by any federal or state agency or franchising authority on the transaction between the operator and the subscriber. An operator shall notify in writing, the Department, the issuing authority, and all affected subscribers of any such change as soon as possible.

(3) Every cable television operator shall fully disclose in writing all of its programming services and rates, upon request from a subscriber.

(4) Every cable television operator shall fully disclose in writing all of its charges for installation, disconnection, downgrades and upgrades, reconnection, additional outlets, and rental, purchase, and replacement due to damage or theft of equipment or devices used in relation to cable services, upon request from a subscriber.

(5) Every cable television operator shall provide written notice of the charge, if any, for service visits and under what circumstances such charge will be imposed, upon request from a subscriber.

(6) A copy of the cable operator's programming services, rates, and charges shall be filed by March 15th of each year with the Department, the issuing authority, and the operator's local office where it shall be made available for public inspection. If an operator amends its notice after the annual filing, it shall file a copy of the amendment with the Department, the issuing authority, and the operator's local office.

(7) A cable operator shall not charge a subscriber for any service or equipment that the subscriber has not affirmatively requested by name. This provision, however, shall not preclude the addition or deletion of a specific program from a service offering, the addition or deletion of specific channels from an existing tier of service, or the restructuring or division of existing tiers of service that do not result in a fundamental change in the nature of an existing service or tier of service.

10.03: Form of Bill

(1)The bill for cable television service shall contain the following information in clear, concise, and understandable language and format:

(a) the name, local address and telephone number of the cable television operator. The telephone number shall be displayed in a conspicuous location on

the bill and shall be accompanied by a statement that the subscriber may call this number with any questions or complaints about the bill and or subscribers rights under 207 CMR 10.07 in the event of a billing dispute;

- (b) the period of time over which each chargeable service is billed including prorated periods as a result of establishment and termination of service;
 - (c) the dates on which individually chargeable services were rendered or any applicable credits were applied;
 - (d) separate itemization of each rate, charge, or fee levied or credit applied, including but not be limited to, basic, premium service, and equipment charges, as well as any unit, pay-per-view, or per item charges or fees;
 - (e) the amount of the bill for the current billing period, separate from any prior balance due; and
 - (f) the date on which payment is due from the subscriber.
- (2) Cable operators may identify as a separate line item of each regular subscriber bill the following:
- (a) The amount of the total bill assessed as a franchise fee and the identity of the franchising authority to whom the fee is paid;
 - (b) The amount of the total bill assessed to satisfy any requirements imposed on the cable operator by the franchise agreement to support public, educational, or governmental channels or the use of such channels;
 - (c) The amount of any other fee, tax, assessment, or charge of any kind imposed by any governmental authority on the transaction between the operator and the subscriber. In order for a governmental fee or assessment to be separately identified under 207 CMR 10.03, it must be directly imposed by a governmental body on a transaction between a subscriber and an operator.
- (3) All itemized costs shall be direct and verifiable. Each cable operator shall maintain a document in its public file which shall be available upon request and shall provide the accounting justification for all itemized costs appearing on the bill.

10.04: Advance Billing and Issuance of Bill

- (1) In the absence of a license provision further limiting the period of advance billing, a cable operator may, under uniform, nondiscriminatory terms and conditions, require payment not more than two months prior to the last day of a service period.
- (2) A cable subscriber may voluntarily offer and a cable operator may accept advance payments for periods greater than two months.
- (3) Upon request, a cable television operator shall provide subscribers with a written statement of account for each billing period and a final bill at the time of disconnection.

10.05: Billing Due Dates, Delinquency, Late Charges and Termination of Service

- (1) Subscriber payment to a cable operator is due on the due date marked on the bill, which shall be a date certain and in no case a statement that the bill is due upon receipt. The due date shall not be less than five business days following the mailing date of the bill.
- (2) A subscriber account shall not be considered delinquent unless payment has not been received by the cable operator at least 30 days after the bill due date.
- (3) The following provisions shall apply to the imposition of late charges on cable subscribers:
 - (a) A cable television operator shall not impose a late charge on a subscriber unless a subscriber is delinquent, the operator has given the subscriber a written late charge notice in a clear and conspicuous manner, and the subscriber has been given at least eight business days from the date of delinquency to pay the balance due.
 - (b) A charge of not more than 5% of the balance due may be imposed as a onetime late charge.
 - (c) No late charge may be assessed on the amount of a bill in dispute.
- (4) A cable television operator shall not terminate a subscriber's service unless the subscriber is delinquent, the cable operator has given the subscriber a separate written notice of termination in a clear and conspicuous manner, and the subscriber has been given at least eight business days from the mailing of the notice of termination to pay the balance due. A notice of termination shall not be mailed to subscribers until after the date of delinquency.
- (5) A cable television operator shall not assess a late charge on a bill or discontinue a subscriber's cable television service solely because of the nonpayment of the disputed portion of a bill during the period established by 207 CMR 10.07 for registration of a complaint with the operator or during the process of a dispute resolution mechanism recognized under 207 CMR 10.07.
- (6) Any charge for returned checks shall be reasonably related to the costs incurred by the cable operator in processing such checks.

10.06: Charges for Disconnection or Downgrading of Service

- (1) A cable television operator may impose a charge reasonably related to the cost incurred for a downgrade of service, except that no such charge may be imposed when:
 - (a) A subscriber requests total disconnection from cable service; or
 - (b) A subscriber requests the downgrade within the 30 day period following the notice of a rate increase or a substantial change in the number or type of programming services relative to the service(s) in question.

- (2) If a subscriber requests disconnection from cable television service prior to the effective date of an increase in rates, the subscriber shall not be charged the increased rate if the cable television operator fails to disconnect service prior to the effective date. Any subscriber who has paid in advance for the next billing period and who requests disconnection from service shall receive from the cable operator a prorated refund of any amounts paid in advance.

10.07: Billing Disputes

- (1) Every cable television operator shall have established procedures for prompt investigation of any billing dispute registered by a subscriber. The procedures shall provide at least 30 days from the due date of the bill for the subscriber to register a complaint. The cable television operator shall notify the subscriber of the result of its investigation and give an explanation for its decision within 30 business days of receipt of the complaint.
- (2) The subscriber forfeits any rights under 207 CMR 10.07 if he or she fails to pay an undisputed balance within 30 days of the bill due date.
- (3) Any subscriber who disagrees with the results of the cable television operator's investigation must promptly inquire about and take advantage of any complaint resolution mechanism, formal or informal, available under the license or through the issuing authority before the Department may accept a petition filed under 207 CMR 10.07(4).
- (4) The subscriber or the cable television operator may petition the Department to resolve disputed matters within 30 days of any final action by the cable operator. Final action under 207 CMR 10.07(3) shall be deemed to have occurred 30 days after the filing of a complaint.
- (5) Upon receipt of a petition, the Department may proceed to resolve the dispute if all parties agree to submit the dispute to the Department and be bound by the Department's decision and the Department obtains a statement signed by the parties indicating that agreement. In resolving the dispute, the Department may receive written or oral statements from the parties and may conduct its own investigation. The Department shall then issue a decision based on the record and the parties shall receive written notification of the decision and a statement of reasons therefor.

10.08: Security Deposits

- (1) A cable operator shall not require from any cable subscriber a security deposit for converters or other equipment in excess of the cost of the equipment.
- (2) The cable operator shall pay interest to the cable subscriber at a rate of 7% per year for any deposit held for six months or more, and such interest shall accrue from the date the deposit is made by the cable subscriber. Interest shall be paid annually by the cable operator to the cable subscriber, either as a direct payment or as a credit to the cable subscriber's account.

- (3) Within 30 days after the return of the converter or other equipment, the cable operator shall return the security deposit plus any accrued interest to the cable subscriber, either as a direct payment or as a credit to the cable subscriber's account.

License End

Town Hall, 334 Main Street
Great Barrington, MA 01230

Telephone: (413) 528-1619
Fax: (413) 528-2290



TOWN OF GREAT BARRINGTON
MASSACHUSETTS

PLANNING BOARD

SPECIAL PERMIT # 943-24

NAME, ADDRESS, AND PROJECT: Special Permit application from Zac Culbreth on behalf of Castle Street Firehouse LLC, 50 East Road, West Stockbridge, MA, seeking to deviate from the requirements of Section 6.4.6 of the Zoning Bylaw in order to install upward shining lights on the hose tower of the former fire station at 20 Castle Street, Great Barrington, filed in accordance with Sections 6.4.7 and 10.4.

REVIEW MEETINGS

These Boards and Commissions will hold meetings on the following dates to consider your application and make a recommendation to the Planning Board (dates may be subject to change):

CONSERVATION COMMISSION Wednesday, March 28, 2024, 6:30 PM

** Applicant, call the Conservation Agent in advance of the meeting to see if you should attend.*

BOARD OF HEALTH Thursday, April 4, 2024, 6:30 PM

*** Applicant, call the Health Agent in advance of the meeting to see if you should attend.*

SELECTBOARD Monday, April 8, 2024, 6:00 PM

Applicant must attend in person or via zoom

SPECIAL PERMIT PUBLIC HEARING

The **PUBLIC HEARING** before the **PLANNING BOARD** is scheduled for Thursday, April 25, 2024, at 6:00 PM, at Town Hall with a remote option via Zoom video/teleconference meeting.

Applicant must attend in person or via zoom

Boards or staff may reach out to applicant in order to schedule site visits.

943-24, PB

TOWN OF GREAT BARRINGTON

Application for a Special Permit
to the Board of Selectmen or Planning Board

FOR OFFICE USE ONLY

Number Assigned 943-24 Date Received 3/7/24
Special Permit Granting Authority PB
Copy to Recommending Boards 3/11
Advertised 4/4 & 4/11
Public Hearing 4/25/24
Fee: \$300.00 Paid: yes

APPLICATION FOR SPECIAL
PERMIT UNDER TOWN ZONING
BYLAWS FOR TOWN OF
GREAT BARRINGTON,
MASSACHUSETTS

MAP 019.0 LOT 0087.0 BOOK 417 PAGE 227 ZONING DISTRICT(S) B, VCOD

Site Address: 20 CASTLE ST

Date of Application FEBRUARY 28, 2024

Applicant's name and complete mailing address Zac Culbreth
35 Bridge Street
Great Barrington, MA

Applicant's phone number (401)573-4037 Applicant's email address: zculbreth@zacculbreth.com

Name and Address of Owner of land exactly as it appears on most recent tax bill:

Castle Street Firehouse LLC
50 East Road
West Stockbridge, MA 01266

I (we) request a Special Permit for: Uplighting on the rebuilt hose tower.

Under Section(s) 6.4.6 Lighting and 10.4 of the Great Barrington Zoning Bylaws.

APPLICANTS MUST READ AND COMPLY WITH THE FOLLOWING:

One Signed Original application with each of the items below, as applicable, fourteen (14) exact copies of the entire package, and one electronic PDF, are to be submitted. Applications must include:

1. Completed application form, including signatures.
2. Brief written description of how the project is in harmony with the Great Barrington Master Plan, (Copies of the Master Plan are available for free download from the Town website. Hard copies can be read at the Clerk's office or the Town libraries.)
3. Site Plan, drawn to scale, applicable to the site and the proposed use of said site for which this special permit is requested.
4. Any other specifications necessary to further describe the site or proposed use for which a special permit is requested. At least one copy of any maps being submitted shall be no larger than 11" X 17". Plans should show all existing and proposed structures, property lines and dimensions, driveways, walkways and parking areas. All proposed landscaping, parking, loading, and similar improvements must be in compliance with the applicable sections of the Zoning Bylaw.
5. Certified list of abutters within 300 feet on the Assessors Maps to the subject property, including map and lot number. List must be obtained from the Assessors' Office.

- 6. Zoning Map designating the zoning district(s) and location for the area for which a special permit is requested, plus a USGS map enlarged and showing the site location within the Town.
- 7. Drainage Plan indicating the destination of all runoff from the property. In the event of substantial increase in impervious surfaces, the SPGA may require calculations or expert analysis of the plan.
- 8. Landscaping Plan drawn to scale and showing existing and proposed landscaping.
- 9. If applicant and owner are different, a letter signed by the owner of the property authorizing the applicant to apply for the special permit.

SPECIFICS:

- 1. All site plans and specifications must be signed and dated by the preparer.
- 2. **ALL OWNERS** of property must also sign the application.
- 3. A copy of special permit procedures is available upon request.
- 4. Fee for application is \$300.00 to cover the cost of the public hearing notices in the newspaper and notification to parties in interest.
- 5. Once all the necessary papers, maps, etc. are compiled into the required Original and Fourteen sets, call the Town Planner's office at 413-528-1619 ext. 7 to arrange an appointment to file your application. The application will be reviewed for completeness and a date for a public hearing before the Board of Selectmen or Planning Board will be scheduled. Meetings of recommending boards (e.g. Planning Board, Conservation Commission and Board of Health) will also be arranged at this time.

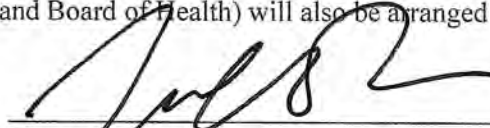

 Signature of Applicant

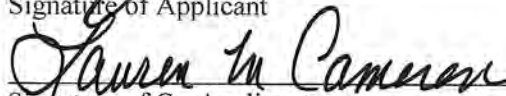

 Signature of Co-Applicant (e.g. Property Owner, if different)

PLEASE READ AND SIGN BELOW

ALL COSTS INCURRED BY THE TOWN FOR THE EMPLOYMENT OF EXPERTS OR CONSULTANTS REQUIRED BY ANY TOWN BOARD, AND APPROVED BY THE BOARD OF SELECTMEN, FOR THE PURPOSE OF ANALYZING OR EVALUATING ANY PROJECT THAT IS A SUBJECT OF A SPECIAL PERMIT APPLICATION SHALL BE ASSESSED TO THE APPLICANT AND SHALL CONSTITUTE PART OF THE APPLICATION FEE. A COPY OF THIS REGULATION SHALL BE PROVIDED TO THE APPLICANT IF REQUESTED.

I have read the above regulation and agree to be bound by it.

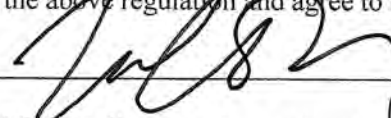
Signature 

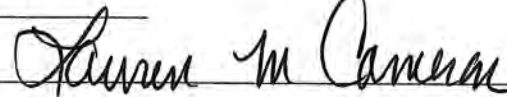
Signature of Co-Applicant (e.g. Property Owner) 

Date 

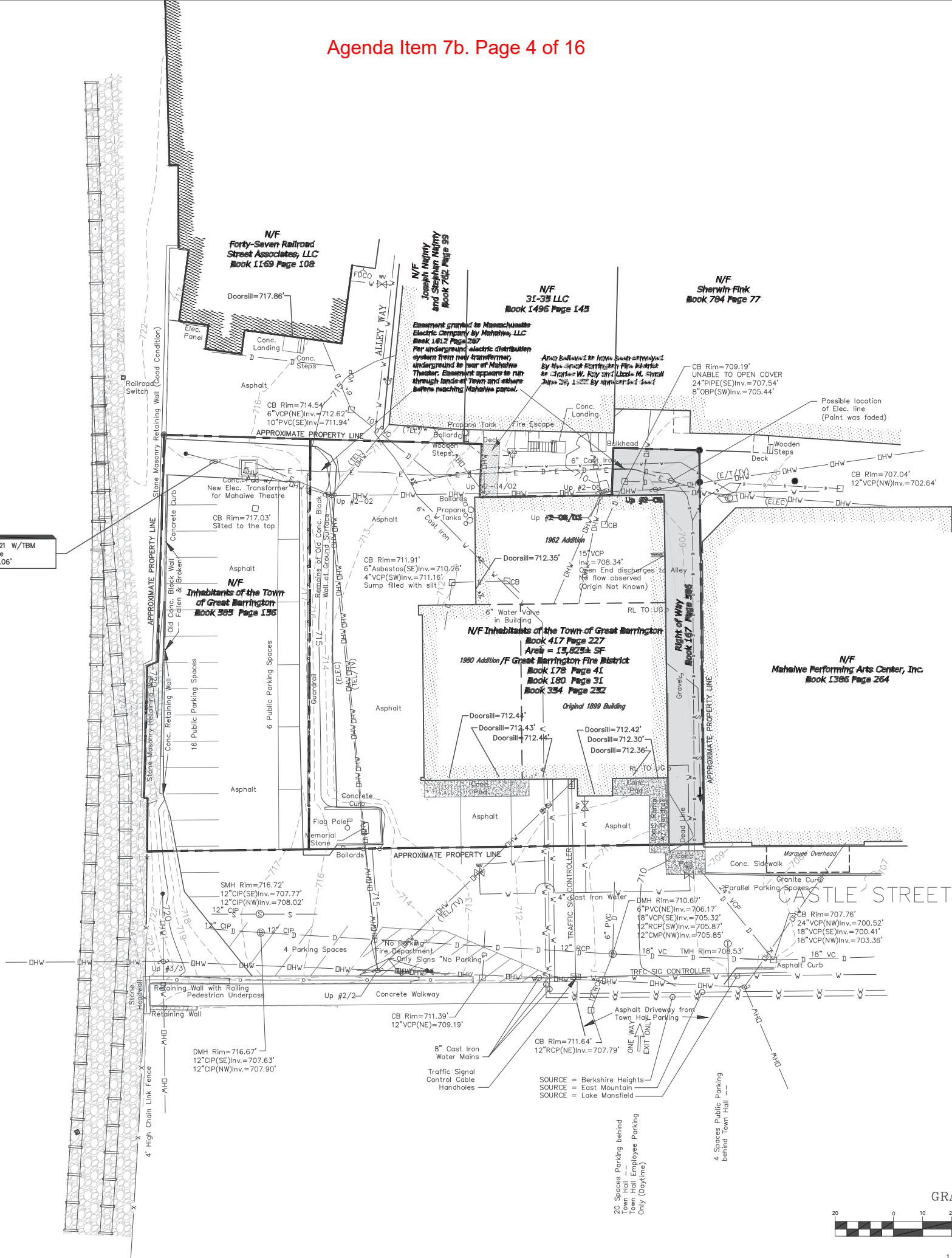
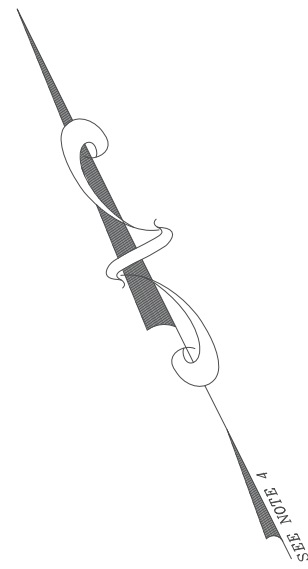

GENERAL NOTES

- Topographic Survey was performed by Foresight Land Services April 26, 27 and May 12, 2005, using Electronic Total Station with Data Collector.
- Plan was compiled on a PC-based computer using 2004 Autodesk Land Desktop.
- Contours are computer-generated interpolations, edited to generally conform to field observations. Contour interval = 1 (one) foot. Contractor shall verify critical elevations and grades in the field prior to construction.
- Horizontal Datum is based upon plan entitled "Station Map-Lands, The New York New Haven and Hartford R.R. Co. operated by The New York New Haven and Hartford R.R. Co. from Bridgeport to Pittsfield, Station 542+01 to Station 594+81, Town of Gt. Barrington, State of Mass., Scale: 1"=100', Dated June 30, 1915.
- The vertical datum is based upon USC&GS brass disk stamped, F 10 1935, located in west side of north abutment about 210 feet south of the NYNH&H Railroad Depot, at bridge 93.79 over Saint James Place, 14 feet west of west rail, about 3 feet lower than the rail. Elevation of brass disk F 10 1935 = 721.21' (NGVD 1929).
- The locations and information about underground pipes, utilities or other structures are compiled from available record data and visible field evidence and are not represented as being exact or complete. Prior to beginning excavation, the excavator shall give adequate advance notice to the Dig Safe Center, the municipal and/or state Public Works Department, and private utility companies, to allow for field location of facilities in the vicinity.
- If Contractor observes any field conditions which vary significantly from what is shown on these plans, the contractor shall immediately notify the Owner and Engineer for resolution of the conflicting information.
- The Contractor shall record tie measurements, depths, dimensions, materials, field conditions and other pertinent data about all underground pipes, utilities and structures encountered during the work, both existing and constructed. Contractor shall submit Record drawings with this information to the Owner and Engineer prior to completion of the work.
- Contractor shall immediately report any damage to existing pipes, utilities, or structures to the Owner and Engineer, and obtain directions as to repair, replacement or abandonment.

LEGEND

- IRON PIPE FOUND
 - BOUND FOUND
 - IRON PIPE TO SET
 - ⊙ DRILL HOLE
 - ⊕ UTILITY POLE
 - ANCHOR
 - ⊕ DRAINAGE MANHOLE
 - ⊕ CATCH BASIN
 - ⊕ HAND HOLE
 - ⊕ WATER VALVE
 - ⊕ FLAG POLE
 - ⊕ MONUMENT
 - ⊕ TELEPHONE MANHOLE
 - BOLLARD
 - PROPANE TANK
 - ⊕ RAILROAD SWITCH
 - ⊕ SIGN
- CONC. = CONCRETE
TBM = TEMPORARY BENCHMARK
ELEV. = ELEVATION
- INV. = INVERT
UP = UTILITY POLE
CB = CATCH BASIN
- DMH = DRAINAGE MANHOLE
TMH = TELEPHONE MANHOLE

- EDGE OF ASPHALT
- EDGE OF CONCRETE
- PAINTED LINE
- 1' CONTOUR LINE
- 5' CONTOUR LINE
- CHAIN LINK FENCE
- GUARDRAIL
- HANDRAIL
- W WATER LINE
- E ELECTRICAL LINE
- D DRAINAGE LINE
- S SEWER LINE
- OHW OVERHEAD WIRE
- PROPERTY LINE

| MARK | DATE | REVISION | BY |
|------|---------|---|------|
| 1 | 6/23/05 | Update Topo and Property Line Information | APYD |

Topographic Survey
Prepared For
GREAT BARRINGTON FIRE DISTRICT
Castle Street
Great Barrington, MA

PREPARED BY:
FORESIGHT LAND SERVICES
Division of Brown Associates, Inc.
Foresight Building • Pittsfield, MA 01201 • Tel (413) 499-1560

SCALE: 1" = 20'
DATE: June 14, 2005
JOB NO. S2113

DWG. NO. S2113W01
CHK. BY: JMC
SHEET NO. 1 OF 1

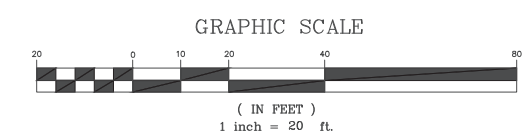

ELECTRICAL LEGEND

- ⊕ 15" Exterior Rated Duplex Outlet
- ⊙ Recessed Light Fixture
- ⊙ Surface Mount Light Fixture
- ⊙ Pendant Light Fixture
- ⊙ Wall Mounted Light Fixture
- ⊙ Ground Mounted Accent Light

ELECTRICAL NOTES

1. All Electrical To Comply With All Pertinent State And Local Codes
2. Coordinate Fixture Location & Wiring With E-100 Lighting & Power Plans
3. Reference Exterior Elevations For Lighting Heights & Placement
4. Reference Lighting Fixture Cut Sheets For Fixture Specifications



ZAC CULBRETH
ARCHITECTURE
35 BRIDGE STREET
GREAT BARRINGTON
MA 01230

PROJECT #1916
PRINTING NOTE:
Formatted For
24 x 36 in Sheets

DO NOT SCALE
DRAWINGS

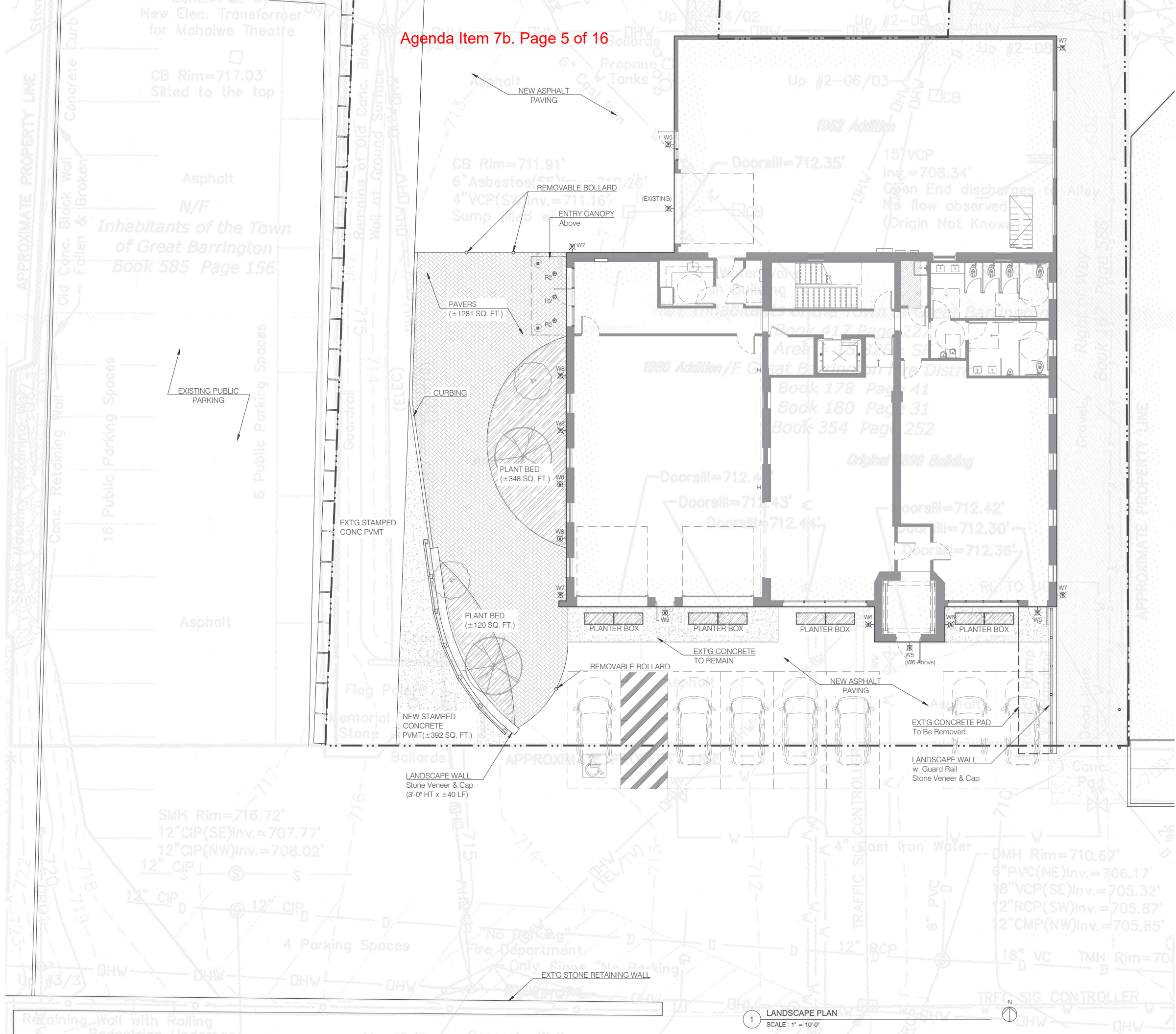

**HISTORIC
FIREHOUSE**
RENOVATIONS
20 CASTLE ST.
GREAT BARRINGTON, MA 01230



REVISIONS:

| | | |
|----|---|------------|
| #1 | (Landscape Updates) | 09/13/2023 |
| #2 | (RCP Updates) | 09/26/2023 |
| #3 | (General Updates) | 10/03/2023 |
| #4 | (Bathroom Walls, Entry Canopy) | 11/29/2023 |
| #5 | (Acoustic Wall Type, Entry Canopy DTLs) | 12/21/2023 |

CONSTRUCTION
DOCUMENTS
FEBRUARY 28, 2024

PROPOSED
LANDSCAPE PLAN

L-001

1 LANDSCAPE PLAN
SCALE: 1" = 10'-0"



ZAC CULBRETH
ARCHITECTURE
35 BRIDGE STREET
GREAT BARRINGTON
MA 01230

PROJECT #1916
PRINTING NOTE:
Formatted For
24 x 36 in Sheets

DO NOT SCALE
DRAWINGS

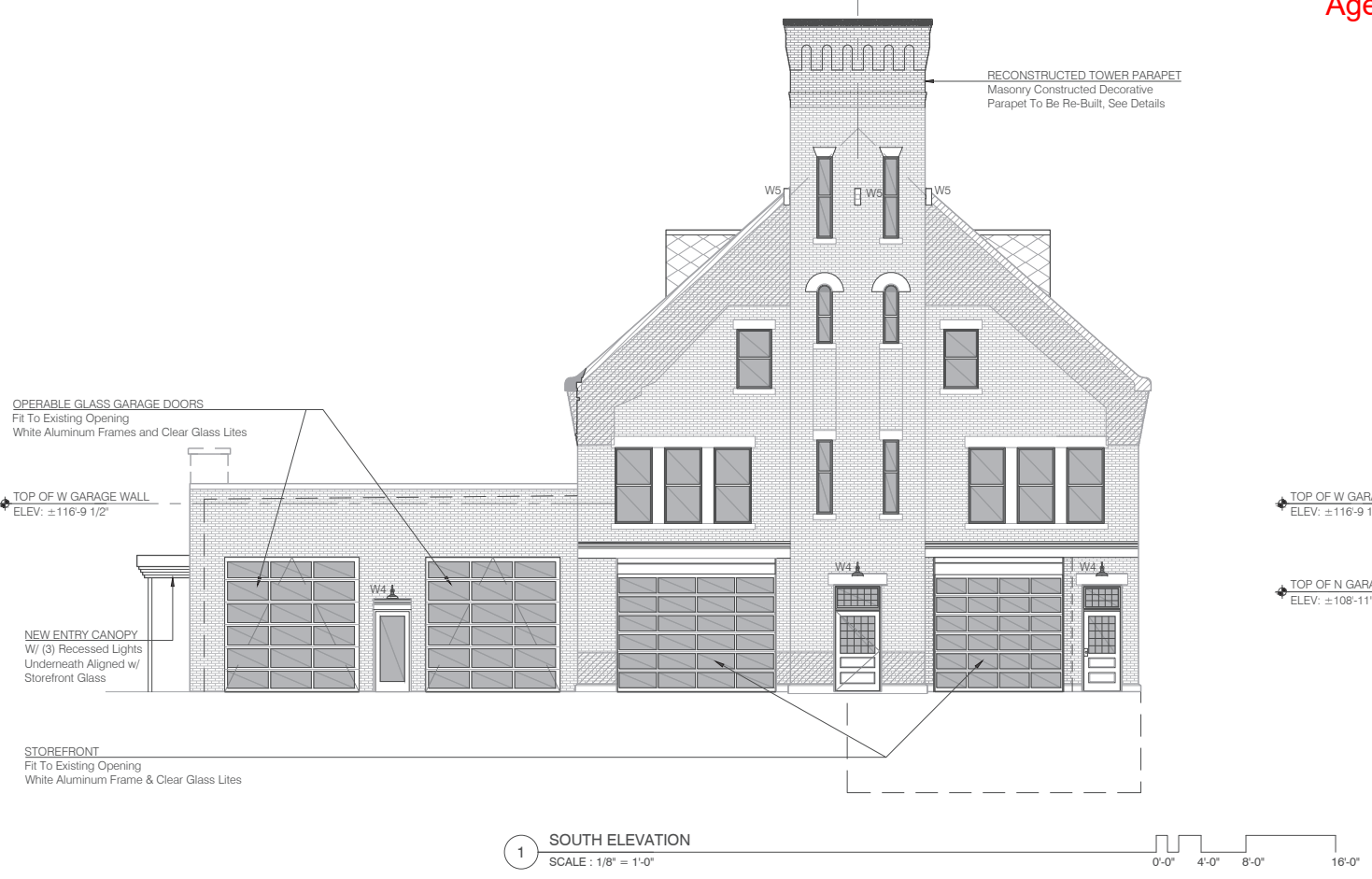

1 SOUTH ELEVATION
SCALE : 1/8" = 1'-0"

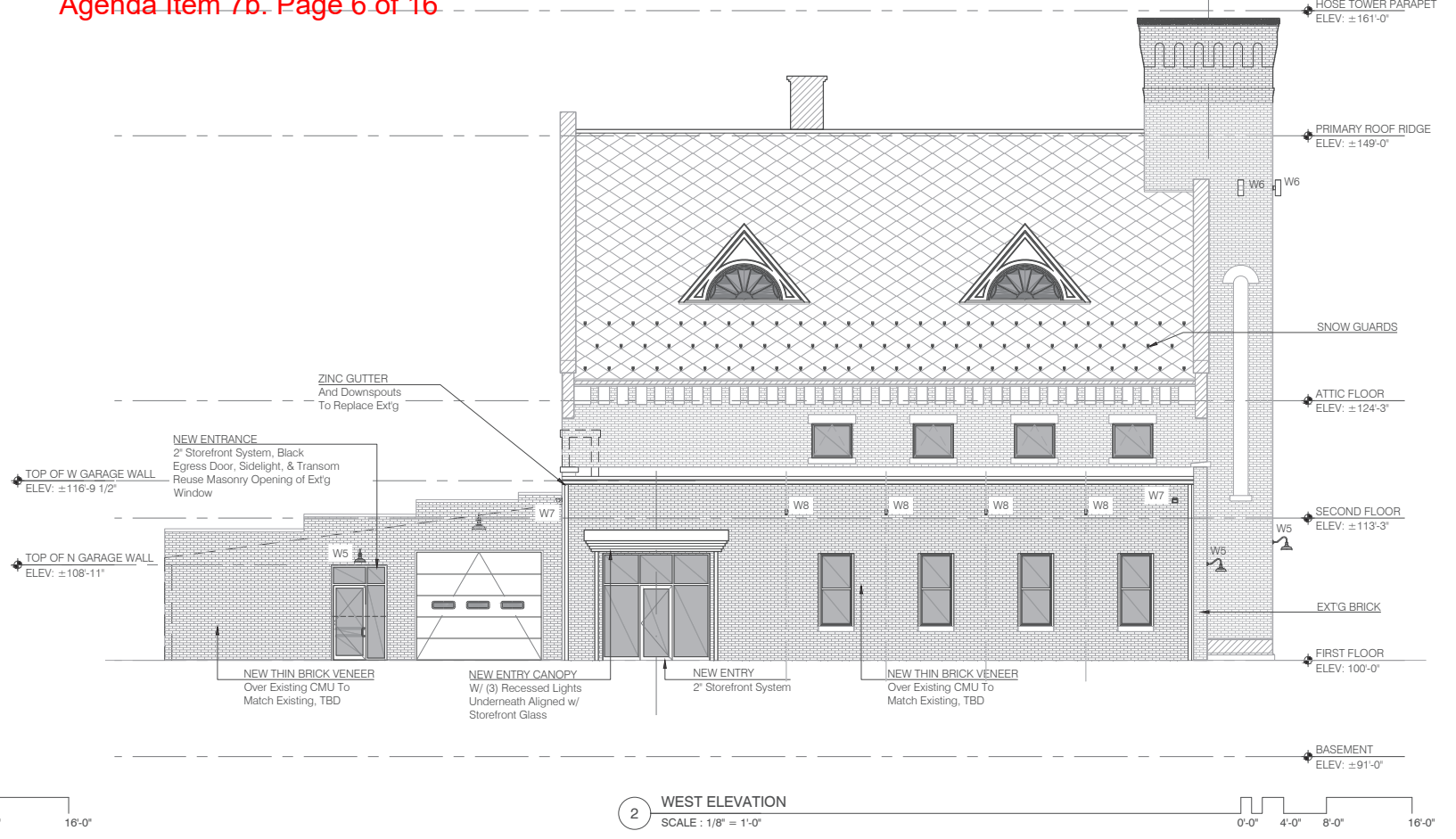

2 WEST ELEVATION
SCALE : 1/8" = 1'-0"

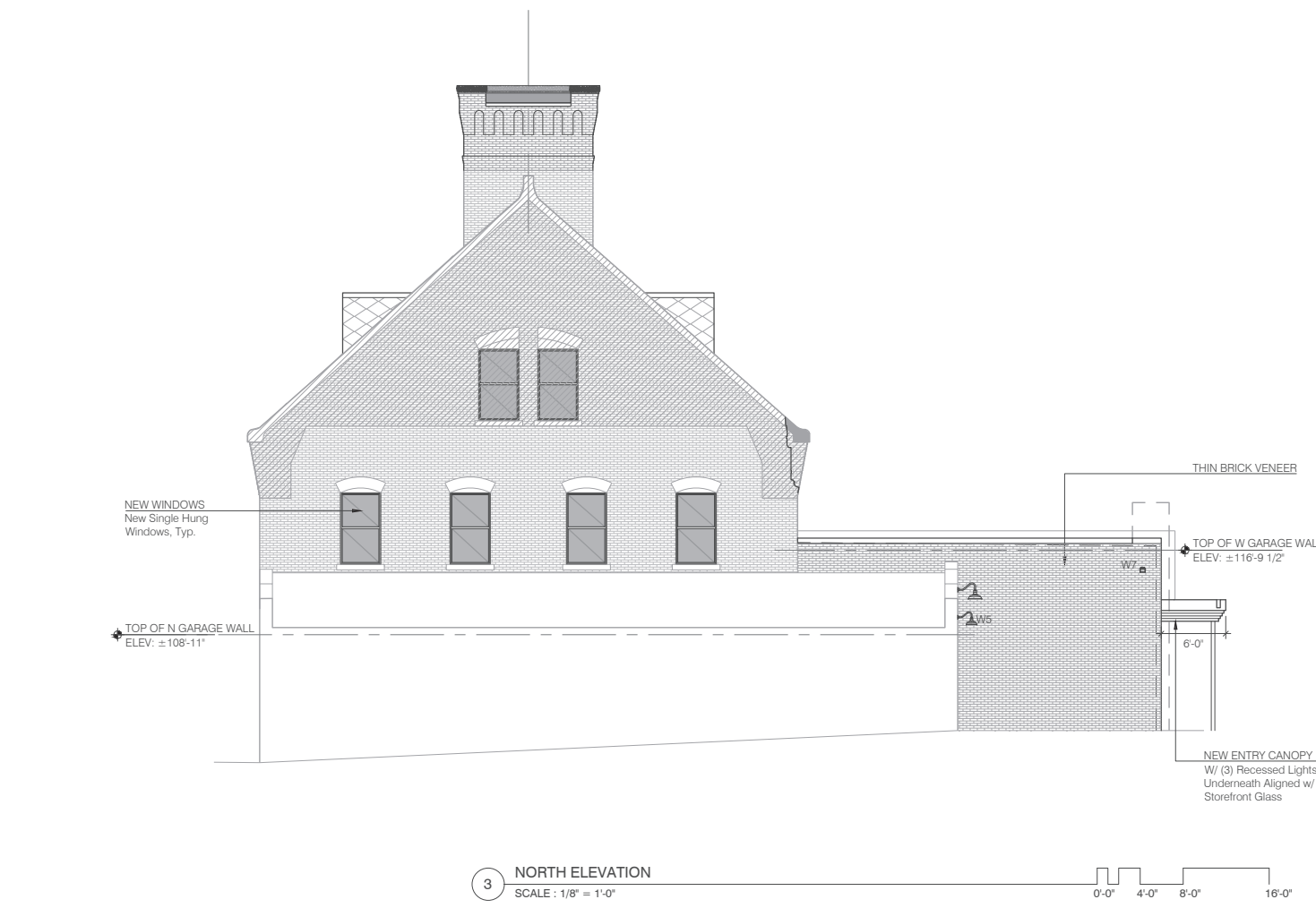

3 NORTH ELEVATION
SCALE : 1/8" = 1'-0"

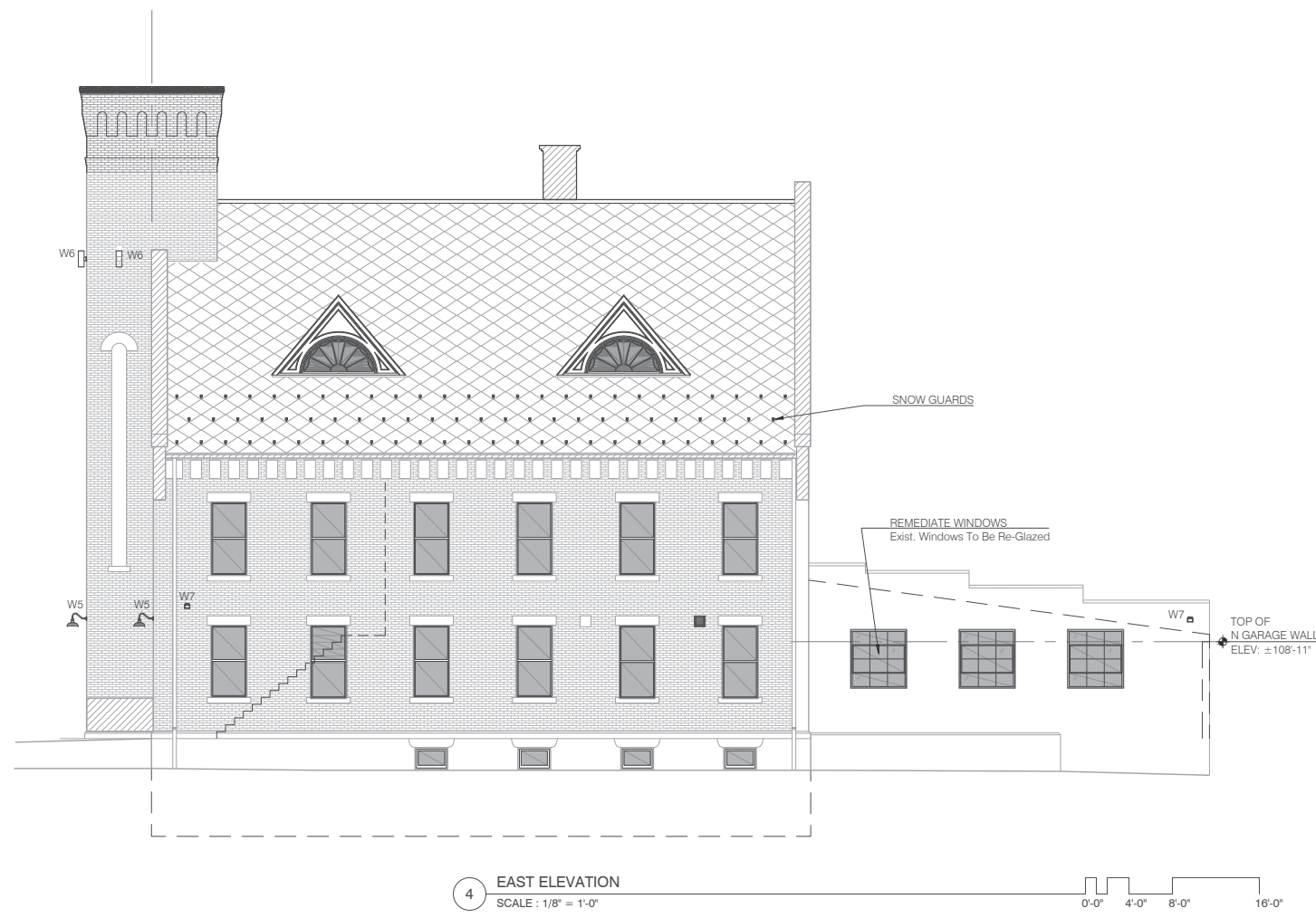

4 EAST ELEVATION
SCALE : 1/8" = 1'-0"

HISTORIC
FIREHOUSE
RENOVATIONS
20 CASTLE ST.
GREAT BARRINGTON, MA 01230

| REVISIONS: | |
|------------|---|
| #1 | 09/13/2023 (Landscape Updates) |
| #2 | 09/26/2023 (RCP Updates) |
| #3 | 10/03/2023 (General Updates) |
| #4 | 11/29/2023 (Bathroom Walls, Entry Canopy) |
| #5 | 12/21/2023 (Acoustic Wall Type, Entry Canopy DTLs) |

CONSTRUCTION
DOCUMENTS
FEBRUARY 28, 2024

EXTERIOR
ELEVATIONS

A-201



ZAC CULBRETH
ARCHITECTURE
35 BRIDGE STREET
GREAT BARRINGTON
MA 01230

PROJECT #1916
PRINTING NOTE:
Formatted For
24 x 36 in Sheets

DO NOT SCALE
DRAWINGS



**HISTORIC
FIREHOUSE**
RENOVATIONS
20 CASTLE ST.
GREAT BARRINGTON, MA 01230



| REVISIONS: | |
|---|------------|
| #1 (Landscape Updates) | 09/13/2023 |
| #2 (RCP Updates) | 09/26/2023 |
| #3 (General Updates) | 10/03/2023 |
| #4 (Bathroom Walls, Entry Canopy) | 11/29/2023 |
| #5 (Acoustic Wall Type, Entry Canopy DTLs) | 12/21/2023 |

CONSTRUCTION
DOCUMENTS
FEBRUARY 28, 2024

EXTERIOR VIEWS

1 EXTERIOR LIGHTING RENDERING
SCALE : NTS

A-210

FLOOD/FLOOD PRO Endurance Wallpack



WP-LED335/WP-LED354



Includes two canopy accessories for surface mount
Or recessed junction boxes

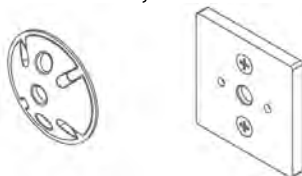

Fixture Type: W6 FIXTURE

Catalog Number:

Project:

Location:

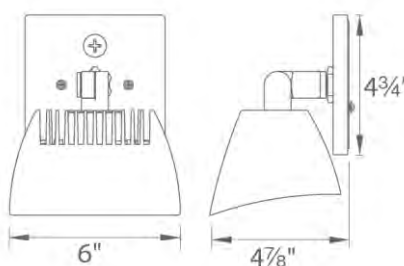

PRODUCT DESCRIPTION

Die cast aluminum factory sealed housings with patent pending design for a water and dust proof IP66 rated outdoor luminaire

FEATURES

- Factory-Sealed LED Light Engine
- 360° Horizontal Rotation, 90° Vertical Aiming
- Photo/Motion Sensor Compatible (Sold Separately)
- Suitable to install in all directions
- 120V Direct Wire - No Driver Needed
- Smooth and Continuous ELV Dimming
- 90 CRI
- 54,000 hour rated life

SPECIFICATIONS

- Construction:** Die-cast aluminum
- Power:** Line Voltage input (120V)
- Dimming:** 100% - 10% with Electronic Low Voltage (ELV) dimmer
- Finish:** Architectural Bronze, White and Graphite
- Standards:** IP66, Wet Location, ETL & cETL Listed
- Operating Temperature:** -40°C (-40°F) to 40°C (104°F)

PHOTOMETRY

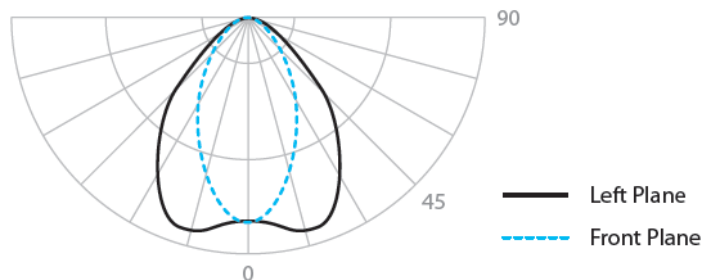

ORDER NUMBER

| Model | | Wattage | Comparable | Color temp | Delivered Lumens | Finish |
|------------------|------------------|---------|------------|------------|------------------|--|
| WP-LED335 | <i>Flood</i> | 35.5W | 100W HID | 30 | 2450 | aBK Architectural Black aBZ Architectural Bronze aGH Architectural graphite aWT Architectural White |
| | | | | 50 | 2730 | |
| WP-LED354 | <i>Flood Pro</i> | 53W | 150W HID | 35 | 3445 | |

Example: **WP-LED354-35-aWT**

wacighting.com
Phone (800) 526.2588
Fax (800) 526.2585

Headquarters/Eastern Distribution Center
44 Harbor Park Drive
Port Washington, NY 11050

Central Distribution Center
1600 Distribution Ct
Lithia Springs, GA 30122

Western Distribution Center
1750 Archibald Avenue
Ontario, CA 91760

FLOOD/FLOOD PRO Endurance Wallpack

WAC LIGHTING

WP-LED335/WP-LED354

MOTION SENSOR (120V) available in 3 complementary colors

PHOTOSENSOR (120V) available in 3 complementary colors



- MS-120-BZ** Bronze
- MS-120-GY** Gray
- MS-120-WT** White

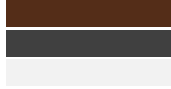

- PC-120-BZ** Bronze
- PC-120-GY** Gray
- PC-120-WT** White

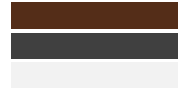

waclighting.com
Phone (800) 526.2588
Fax (800) 526.2585

Headquarters/Eastern Distribution Center
44 Harbor Park Drive
Port Washington, NY 11050

Central Distribution Center
1600 Distribution Ct
Lithia Springs, GA 30122

Western Distribution Center
1750 Archibald Avenue
Ontario, CA 91760

TUBE ARCHITECTURAL DS-WD06

WAC LIGHTING

LED Wall Mounts

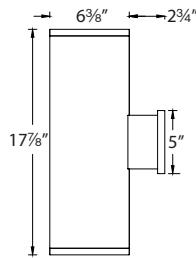

Fixture Type:

W5 FIXTURE

Catalog Number:

Project:

Location:

PRODUCT DESCRIPTION

The latest energy efficient LED technology in an appealing cylindrical profile delivers accent and wall wash lighting. Comes in various light distribution and beam angle options.

FEATURES

- High performance exterior rated LED wall mount light
- Fixture can install upside down to alter light distribution
- Solid aluminum construction
- 5 year warranty

SPECIFICATIONS

- Input:** Universal voltage 120V - 277VAC, 50/60Hz
- Dimming:** Electronic low voltage (ELV) : 100% - 5%
0-10V: 100% - 1%
- Light Source:** High output 3 Step Mac Adam Ellipse COB
Rated life of 60,000 hours at L70
- Finish:** Electrostatically powder coated, white, black, bronze and graphite
- Standards:** IP65 rated, ETL & cETL wet location listed
Title 24 JA8-2016 Compliant
- Operating Temp:** -13°F to 122°F (-25°C to 50°C)

ORDERING NUMBER

| Diameter | Watt | Beam | Beam Angle | Color Temp | CRI | Reference Output ¹ | | Efficacy (lm/w) | Light Distribution | Finish | |
|--------------------|------------|---------------------------|------------|------------|----------|-------------------------------|----------|--|--------------------|--------|--|
| | | | | | | Lumen | CBCP | | | | |
| DS-WD06 | 6" 35W x 2 | S Straight up and down | 16° | 927S | 2700K | 90 | 2820 x 2 | 18842 x 2 | 81 x 2 | | BK Black WT White BZ Bronze GH Graphite |
| | | | | 27S | 2700K | 85 | 3385 x 2 | 22608 x 2 | 97 x 2 | | |
| | | | | 930S | 3000K | 90 | 2925 x 2 | 19543 x 2 | 84 x 2 | | |
| | | | | 30S | 3000K | 85 | 3535 x 2 | 23632 x 2 | 101 x 2 | | |
| | | | | 35S | 3500K | 85 | 3630 x 2 | 24255 x 2 | 104 x 2 | | |
| | | | | 40S | 4000K | 85 | 3665 x 2 | 24490 x 2 | 105 x 2 | | |
| | | N Straight up and down | 28° | 927S | 2700K | 90 | 2800 x 2 | 7992 x 2 | 80 x 2 | | |
| | | | | 27S | 2700K | 85 | 3360 x 2 | 9589 x 2 | 96 x 2 | | |
| | | | | 930S | 3000K | 90 | 2900 x 2 | 8290 x 2 | 83 x 2 | | |
| | | | | 30S | 3000K | 85 | 3510 x 2 | 10024 x 2 | 100 x 2 | | |
| | | | | 35S | 3500K | 85 | 3600 x 2 | 10288 x 2 | 103 x 2 | | |
| | | | | 40S | 4000K | 85 | 3635 x 2 | 10388 x 2 | 104 x 2 | | |
| | | F Straight up and down | 38° | 927S | 2700K | 90 | 2825 x 2 | 5451 x 2 | 81 x 2 | | |
| | | | | 27S | 2700K | 85 | 3390 x 2 | 6540 x 2 | 97 x 2 | | |
| | | | | 930S | 3000K | 90 | 2930 x 2 | 5654 x 2 | 84 x 2 | | |
| 30S | 3000K | | | 85 | 3545 x 2 | 6836 x 2 | 101 x 2 | | | | |
| 35S | 3500K | | | 85 | 3640 x 2 | 7017 x 2 | 104 x 2 | | | | |
| 40S | 4000K | | | 85 | 3675 x 2 | 7085 x 2 | 105 x 2 | | | | |
| DS-WD0644 | 6" 22W x 2 | F Away from the wall | N/A | 927A | 2700K | 90 | 2860 x 2 | N/A | 82 x 2 | | |
| | | | | 27A | 2700K | 85 | 3435 x 2 | N/A | 98 x 2 | | |
| | | | | 930A | 3000K | 90 | 2970 x 2 | N/A | 85 x 2 | | |
| | | | | 30A | 3000K | 85 | 3590 x 2 | N/A | 103 x 2 | | |
| | | | | 35A | 3500K | 85 | 3685 x 2 | N/A | 105 x 2 | | |
| | | | | 40A | 4000K | 85 | 3720 x 2 | N/A | 106 x 2 | | |
| | | F Towards the wall | N/A | 927B | 2700K | 90 | 2860 x 2 | N/A | 82 x 2 | | |
| | | | | 27B | 2700K | 85 | 3435 x 2 | N/A | 98 x 2 | | |
| | | | | 930B | 3000K | 90 | 2970 x 2 | N/A | 85 x 2 | | |
| | | | | 30B | 3000K | 85 | 3590 x 2 | N/A | 103 x 2 | | |
| | | | | 35B | 3500K | 85 | 3685 x 2 | N/A | 105 x 2 | | |
| | | | | 40B | 4000K | 85 | 3720 x 2 | N/A | 106 x 2 | | |
| F One side each | N/A | 927C | 2700K | 90 | 2860 x 2 | N/A | 82 x 2 | One side away from wall, one side towards the wall | | | |
| | | 27C | 2700K | 85 | 3435 x 2 | N/A | 98 x 2 | | | | |
| | | 930C | 3000K | 90 | 2970 x 2 | N/A | 85 x 2 | | | | |
| | | 30C | 3000K | 85 | 3590 x 2 | N/A | 103 x 2 | | | | |
| | | 35C | 3500K | 85 | 3685 x 2 | N/A | 105 x 2 | | | | |
| | | 40C | 4000K | 85 | 3720 x 2 | N/A | 106 x 2 | | | | |

DS-WD06-_____ - _____ Example: **DS-WD06-F930A-WT** ¹Reference output shows 35W output. Multiply by 0.7 to determine output for 22W combinations.

wacighting.com
Phone (800) 526.2588
Fax (800) 526.2585

Headquarters/Eastern Distribution Center
44 Harbor Park Drive
Port Washington, NY 11050

Central Distribution Center
1600 Distribution Ct
Lithia Springs, GA 30122

Western Distribution Center
1750 Archibald Avenue
Ontario, CA 91760

| | | | | | | | | | |
|------------------------|--------------------|----------------|------|----------------|----------------|----------------------|-----------|------|-----------------|
| CHANDELIERS & PENDANTS | BATH & WALL LIGHTS | CEILING LIGHTS | FANS | OUTDOOR LIGHTS | LAMPS & SHADES | MIRRORS & HOME DECOR | FURNITURE | RUGS | NEW & INSPIRING |
|------------------------|--------------------|----------------|------|----------------|----------------|----------------------|-----------|------|-----------------|

Home / OUTDOOR LIGHTS / All Outdoor Lights / Sleek Workshop Outdoor Sconce

Share f t p s e

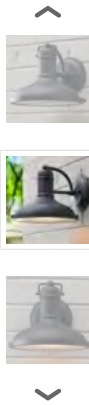

SLEEK WORKSHOP OUTDOOR SCONCE

SKU 0L18072 BK
\$85.00

Actual Size: 7.25"Hx9"Wx10"D

In stock and ready to ship

Qty 1

ADD TO CART

+ Add to Wish List

+ Add to Gift Registry

Description

This metal indoor-outdoor wall light soothes with a matte finish and gentle curves that soften a classic industrial design. Give your porch, exterior walls, or interior hallways a modern farmhouse flair with this elegant and versatile sconce.

- Actual Size: 7.25"Hx9"Wx10"D
- Backplate/Canopy Size: 5"W Round
- Bulb Base: US Medium-E26
- Color: Black
- Dimmable: Yes
- Indoor-Outdoor: Yes
- Material: Glass, Metal
- Max Bulb Wattage: 60
- Number of Lights: 1
- Safety Rating: Wet
- Weight: 15.43

California Residents See PROP 65 WARNINGS

Reviews

EXPAND +

SHOP COLLECTION

VIEW ALL

Agenda Item 7b. Page 12 of 16

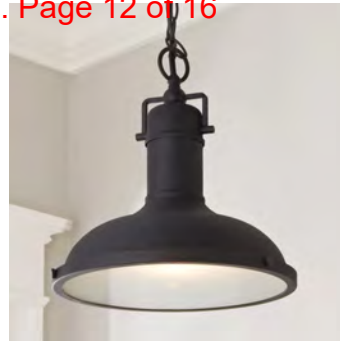

SLEEK WORKSHOP OUTDOOR CEILING LIGHT

SLEEK WORKSHOP OUTDOOR PENDANT

\$79.00

\$104.00

OUR STORY

STORES

CATALOG

CONTACT

STAY IN THE KNOW

Be the first to find out about trending styles, new releases and sales.

Enter Email



Resources

- Request a Catalog
- Designer Trade Program
- Hospitality
- Careers
- Site Map

Customer Service

- Shipping Information
- Returns & Exchanges
- Contact Us

Blog

- Inspired Spaces Blog
- As Seen In
- Design Guides
- Styles & Trends

SHOP NOW >

FEATURES & SPECIFICATIONS

INTENDED USE

The Alcon Lighting **Padova** Architectural LED Directional Up Light Fixture features naturally etched finishes capable of withstanding the test of time. The Padova Directional Uplights are ideal for architectural landscape lighting applications.

DETAILS

L 5.5" x **Dia** 2.25"

Construction: Aluminum

Lens: Clear and heat resistant tempered glass

Wiring: Prewired with a 3' 18-2 SPT2-W direct burial cord

Socket: Top grade fixed ceramic bi-pin with retention clip

Gasket: Silicone gasket for water tight seal

Knuckle: Adjustable die-cast aluminum knuckle with Philips screw. 1/2" NPT threaded male hub on bottom

Mounting: 6" aluminum spike with 1/2" NPT threaded female hub (1/2" NPT Spike included)

Electrical: Remote 12V transformer required (Not included)

Halogen Equivalent: MR16, 20W max

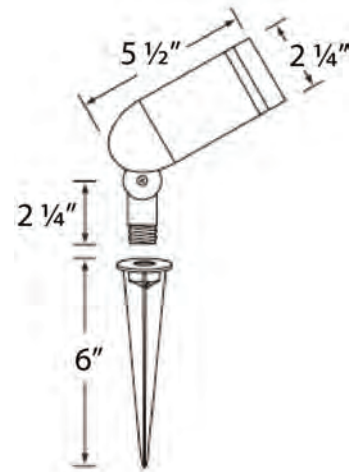

ADDITIONAL FEATURES

Voltage: 12V AC/DC

Wattage: 2.5W

Lumens: 180 lms

Beam Spread: 38° Flood

Color Temperature: 2700K

CRI: 80

Ambient Temperature: -22°F - 122°F

Life: 50,000 Hrs

Warranty: 1 Year Manufacturer Warranty

5 Year Limited Warranty on LED

Ordering Information:

Example: (9018-BK)

| Model | Finish | Mounting |
|-------|-------------------|--|
| 9018 | BK Black | (Blank) 1/2" NPT Spike Included |
| | BZ Bronze | MC Mounting Canopy |
| | VG Verde Green | MS6 6" Mounting Stem |
| | | MS12 12" Mounting Stem |
| | | MS18 18" Mounting Stem |
| | | MS24 24" Mounting Stem |
| | | MP 18" Mounting Pedestal (Black Finish) |

Alcon Lighting 9018 Padova Architectural LED Low Voltage Directional Uplight Landscape Lighting Fixture



300 feet Abutters List Report

Great Barrington, MA
March 04, 2024

Subject Property:

Parcel Number: 19-87-0
CAMA Number: 19-87-0
Property Address: 20 CASTLE ST

Mailing Address: CASTLE STREET FIREHOUSE LLC
PO BOX 522
WEST STOCKBRIDGE, MA 01266-0522

Abutters:

Parcel Number: 13-154-0
CAMA Number: 13-154-0
Property Address: 34 CASTLE HILL AVE

Mailing Address: GROSSHANDLER SETH WAINWRIGHT
KIM B
292 WHITE HILL RD
HILLSDALE, NY 12529-5838

Parcel Number: 13-169-0
CAMA Number: 13-169-0
Property Address: 54 CASTLE ST

Mailing Address: HARTWELL ROBERT
71 PAYSON AVE
NEW YORK, NY 10034-2767

Parcel Number: 19-52-0
CAMA Number: 19-52-0
Property Address: 52 CASTLE ST

Mailing Address: ALDER CREEK LLC
212 NORTH PLAIN RD
GT BARRINGTON, MA 01230-1276

Parcel Number: 19-52-B
CAMA Number: 19-52-B
Property Address: 46 CASTLE ST

Mailing Address: ALDER CREEK LLC
212 NORTH PLAIN RD
GT BARRINGTON, MA 01230-1276

Parcel Number: 19-52-C
CAMA Number: 19-52-C
Property Address: 50 CASTLE ST

Mailing Address: ALDER CREEK LLC
212 NORTH PLAIN RD
GT BARRINGTON, MA 01230-1276

Parcel Number: 19-52-E
CAMA Number: 19-52-E
Property Address: CASTLE LN

Mailing Address: ALDER CREEK LLC
212 NORTH PLAIN RD
GT BARRINGTON, MA 01230-1276

Parcel Number: 19-52-F
CAMA Number: 19-52-F
Property Address: CASTLE ST

Mailing Address: TOWN OF GREAT BARRINGTON
PEDESTRIAN UNDERPASS
334 MAIN ST RM 208
GT BARRINGTON, MA 01230-1832

Parcel Number: 19-67-0
CAMA Number: 19-67-0
Property Address: 80 RAILROAD ST

Mailing Address: SCHNEYER PETER A
PO BOX 1235
SHEFFIELD, MA 01257-1235

Parcel Number: 19-68-0
CAMA Number: 19-68-0
Property Address: 70 RAILROAD ST

Mailing Address: TRIPLEX CINEMA INC
PO BOX 1044
GT BARRINGTON, MA 01230-1044

Parcel Number: 19-69-0
CAMA Number: 19-69-0
Property Address: 284 MAIN ST

Mailing Address: REISTAN ENTERPRISES INC
P O BOX 99
SOUTH EGREMONT, MA 01258-0099



www.cai-tech.com



300 feet Abutters List Report

Great Barrington, MA
March 04, 2024

| | |
|--|---|
| Parcel Number: 19-70-0 CAMA Number: 19-70-0 Property Address: 38 RAILROAD ST | Mailing Address: THIRTY EIGHT RAILROAD LLC P O BOX 99 SOUTH EGREMONT, MA 01258-0099 |
| Parcel Number: 19-71-0 CAMA Number: 19-71-0 Property Address: 20 RAILROAD ST | Mailing Address: COHEN GROUP LLC THE 560 GREYLOCK ST LEE, MA 01238-9395 |
| Parcel Number: 19-72-0 CAMA Number: 19-72-0 Property Address: 14 RAILROAD ST | Mailing Address: BOW TIE LLC 18 RAILROAD LLC 281 MAIN ST SUITE 11 GT BARRINGTON, MA 01230-1617 |
| Parcel Number: 19-73-0 CAMA Number: 19-73-0 Property Address: 8 RAILROAD ST | Mailing Address: TRADING MOON LLC 8 RAILROAD ST GT BARRINGTON, MA 01230-1521 |
| Parcel Number: 19-74-0 CAMA Number: 19-74-0 Property Address: 292 MAIN ST | Mailing Address: WARE BLOCK LLC JAMES KIMBALL 1162 CLAYTON MILL RIVER RD SOUTHFIELD, MA 01259-9776 |
| Parcel Number: 19-76-0 CAMA Number: 19-76-0 Property Address: 47 RAILROAD ST | Mailing Address: 47 RAILROAD LLC SAMUEL NICKERSON 13 POTHUL DR GT BARRINGTON, MA 01230-1025 |
| Parcel Number: 19-77-0 CAMA Number: 19-77-0 Property Address: 39 RAILROAD ST | Mailing Address: GRANTVILLE PROPERTIES MA LLC PO BOX 26 NORFOLK, CT 06058-0026 |
| Parcel Number: 19-78-0 CAMA Number: 19-78-0 Property Address: 31 RAILROAD ST | Mailing Address: 31-35 LLC C/O ROBERT NAVARINO 31 RAILROAD ST GT BARRINGTON, MA 01230-1577 |
| Parcel Number: 19-79-0 CAMA Number: 19-79-0 Property Address: 25 RAILROAD ST | Mailing Address: F SCOTT FINK LLC 30 ORCHARD LANE HILLSDALE, NY 12529-6008 |
| Parcel Number: 19-80-0 CAMA Number: 19-80-0 Property Address: 19 RAILROAD ST | Mailing Address: MARCUS J MICHAEL TRUSTEE BIZEN NOMINEE REALTY TRUST 19 RAILROAD ST GT BARRINGTON, MA 01230-1577 |
| Parcel Number: 19-81-0 CAMA Number: 19-81-0 Property Address: 9 RAILROAD ST | Mailing Address: C&G SMART MOVE LLC 50 CHURCH ST LENOX, MA 01240-2554 |
| Parcel Number: 19-82-0 CAMA Number: 19-82-0 Property Address: 304 MAIN ST | Mailing Address: MERCER JAMES J TRUSTEE WESTGOOD REALTY TRUST 80 MAPLE AVE SUITE 1 GT BARRINGTON, MA 01230-2211 |

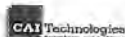

www.cai-tech.com



300 feet Abutters List Report

Great Barrington, MA
March 04, 2024

| | |
|---|---|
| Parcel Number: 19-83-0 CAMA Number: 19-83-0 Property Address: 308 MAIN ST | Mailing Address: CDCSB SUMNER BLOCK INC 40 RAILROAD ST #8 GT BARRINGTON, MA 01230-1570 |
| Parcel Number: 19-84-0 CAMA Number: 19-84-0 Property Address: 7 RAILROAD ST | Mailing Address: 7 RAILROAD STREET LLC 231 HARTSVILLE NEW MARLBOROUGH NEW MARLBOROUGH, MA 01230 = 2055 |
| Parcel Number: 19-85-0 CAMA Number: 19-85-0 Property Address: CASTLE ST | Mailing Address: INHABITANTS OF THE TOWN OF GREAT BARRINGTON 334 MAIN ST ROOM 208 GT BARRINGTON, MA 01230-1832 |
| Parcel Number: 19-88-0 CAMA Number: 19-88-0 Property Address: 14 CASTLE ST | Mailing Address: MAHAIWE PERFORMING ARTS CENTER INC PO BOX 690 GT BARRINGTON, MA 01230-0690 |
| Parcel Number: 19-89-0 CAMA Number: 19-89-0 Property Address: 312 MAIN ST | Mailing Address: 312 MAIN STREET PARTNERSHIP C/O LOUIS OGGIANI 312 MAIN ST SUITE 3 GT BARRINGTON, MA 01230-1879 |
| Parcel Number: 19-90-0 CAMA Number: 19-90-0 Property Address: 322 MAIN ST | Mailing Address: 322 MAIN LLC PO BOX 627 GT BARRINGTON, MA 01230-0627 |
| Parcel Number: 19-91-0 CAMA Number: 19-91-0 Property Address: 334 MAIN ST | Mailing Address: TOWN OF GREAT BARRINGTON TOWN HALL 334 MAIN ST RM 208 GT BARRINGTON, MA 01230-1832 |
| Parcel Number: 19-92-0 CAMA Number: 19-92-0 Property Address: 352 MAIN ST | Mailing Address: ST JAMES PLACE INC 352 MAIN ST GT BARRINGTON, MA 01230-1876 |
| Parcel Number: 19-92-A CAMA Number: 19-92-A Property Address: 342 MAIN ST | Mailing Address: 342 MAIN STREET LLC 342 MAIN ST GT BARRINGTON, MA 01230-1814 |
| Parcel Number: 19-92-B CAMA Number: 19-92-B Property Address: MAIN ST | Mailing Address: ST JAMES PLACE INC 352 MAIN ST GT BARRINGTON, MA 01230-1876 |

The above list of abutters to the subject property is correct according to the latest records of this office.

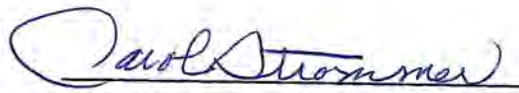
Administrative Assessor



www.cai-tech.com

Data shown on this report is provided for planning and informational purposes only. The municipality and CAI Technologies are not responsible for any use for other purposes or misuse or misrepresentation of this report.

January 20, 2024

RE: Holiday Lighting and Banner Inquiry

Dear Lauren,

In the spirit of community service and within safety parameters, Massachusetts Electric Company allows certain types of decorative Fixtures to be installed on its poles along public ways subject to the enclosed guidelines.

In order for us to evaluate your attachment request, please provide the following information for the designated area:

- Name of organization and contact **Berkshire International Film Festival, Kelley Vickery**
- Complete description of Fixture to be attached **30" x 36" Vinyl Flags**
- Specific Attachment location **9-12 Poles on Main Street between Pleasant and Bridge Street**
- Electrical Service requirements, if any **None**
- Dates that Banners and/or lighting will be in place **Week of April 22 to June 10, 2024**
- Method for attachments and removal of banners and/or lighting **Larkin Sign Co will install and take down signs attached to metal brackets**

Upon evaluation of this information, Massachusetts Electric Company will determine the attachments' compliance with our guidelines, and confirm the ability to proceed upon execution of the referenced guidelines.

Please do not hesitate to contact me at 413-664-5813 if you have any questions or need additional information.

Sincerely,

Joanne DeRose
National Grid
60 Brown Street
North Adams, MA 01247
joanne.derose@us.ngrid.com

January 20, 2024

Name Kelley Vickery

Address 40 Railroad Street, Suite 5-7, Great Barrington, MA 01226

Re: Use of poles for hanging decorative banners

Dear Kelley:

Massachusetts Electric Company ("Mass. Electric") understands that you wish to install certain types of decorative banners, flags, or single pole fixtures on our poles along public ways. Mass. Electric will allow Berkshire International Film Festival ("Customer") to install banners (Fixtures) on our poles along Main Street between Pleasant and Bridge Street and 3 poles on Bridge Street in Great Barrington ("Municipality") for the period of August 9 to September 14 in accordance with the following requirements:

- 1) Prior to installing any Fixtures, Customer must obtain Verizon's approval for installation on any poles that Mass. Electric jointly owns with Verizon and must provide Mass. Electric with written documentation that Municipality approves the installation.
- 2) Customer shall be responsible for the proper installation, maintenance, and future removal of the Fixtures.
- 3) Fixtures may be attached individually on a single pole along the side of the road (not across a roadway) as long as the vertical clearance from the Fixtures to the ground is a minimum of 13 feet over pedestrian walkways, and 16 feet over streets, driveways, loading docks, and anywhere else that there is motorized traffic. Fixtures must be installed below the lowest telephone cables on the pole. Note that this requirement may make the height of the Fixtures less than the minimum required in places, and bar installation at those places unless the size of the fixture is decreased. Fixtures may not be installed between two wooden or aluminum poles along or across a roadway.
- 4) The maximum size of any Fixtures is 30" x 36", with a maximum weight not to exceed 5 pounds. Customer shall not use any Fixtures that require electric service or batteries to operate.
- 5) Customer shall use band clamps to install the Fixtures and may not drill into the poles.
- 6) Customer or its contractor shall install the Fixtures at the Customer's expense.
- 7) Mass. Electric reserves the right to remove the Fixtures at any time Mass. Electric deems it necessary for the maintenance or operation of its poles. If Mass. Electric determines, in its sole discretion, that a pole is damaged for any reason and must be replaced, Mass. Electric will remove the pole and may dispose of any Fixtures on that pole. In all instances, Mass. Electric shall have no responsibility to replace the Fixtures or reimburse Customer for them.

8) Customer agrees to remove any Fixtures at Mass. Electric's request if, in Mass. Electric's opinion, the Fixtures begin to deteriorate or are deemed offensive or a safety hazard to any residents or public officials.

9) Customer warrants that it is an association, institution, non-profit organization, or other entity operating for the public good, and not a commercial entity. Customer agrees not to install any commercial advertising on the Fixtures. Customer may, however, put up to two sponsor logos in the lower corner of the Fixture, if they take up less than 1/10 of the Fixtures' area.

10) The Customer will provide an insurance certificate naming Mass. Electric as an additional insured in the amount of \$2 million.

11) Mass. Electric shall not be liable to the Customer, its officers, employees, agents or contractors under any legal or equitable theory for any claims for direct, indirect, consequential, or other damages of any nature including, but not limited to, damages for personal injury, property damage, or lost profits connected with the installation of the Fixtures.

12) Customer agrees to indemnify and save harmless Mass. Electric, its affiliates, and their employees or agents or any of them from and against any and all liabilities, damages, loss, costs, expenses (including any and all attorneys' fees and expenses of), causes of action, suits, claims, demands or judgments of any nature whatsoever arising from or related to the installation of Fixtures including, without limiting the generality of the foregoing, claims for or resulting from (i) injury to, or the death of, persons or damage to property; or (ii) violation of this agreement or of any applicable federal, state or municipal laws, regulations, codes and ordinances..

If you agree with the terms of this letter, please sign below and return this letter to me. Thank you very much.

Very truly yours,

Joanne DeRose
February 6, 2024

MEC Director

Acknowledged and agreed:

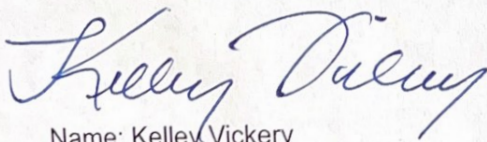

Name: Kelley Vickery

Title: Artistic Director

Organization: Berkshire International Film Festival



Town of Great Barrington

334 Main Street, Great Barrington, MA 01230
(413) 528-1619 x2900 | (413) 528-2290 fax



Board, Committee & Commission Appointment Application Great Barrington Cultural Council

Please accept this application for appointment to the: _____

Name: Peggy Reeves Residential Address: [REDACTED]

Mailing Address (if different): [REDACTED]

Telephone Number: 413 429-1644 E-mail Address: PEARL465@gmail.com

Re-appointment. *If re-appointment, no other information is necessary except signature and date.*

Have you attended a meeting on this Board, Committee or Commission? yes, (March 25)

Reason for applying: _____

I'm interested in lending my support to the cultural experiences that enrich the lives of
all the people of our community.

Relevant experience: _____

Relevant experience: Retired art educator, exhibiting artist, volunteer for cultural organizations,

BIFF, The Triplex, Board member Sculpture Now 2007-2023, Theater photographer, (Mixed Company, Castle Hill Theater Company, New Stage Performing Arts.) Berkshire resident since 1978.

Signature: Peggy Reeves Date: March 26, 2024

*Please feel free to include a copy of your resume and any other relevant materials. Return to the Selectboard/Town Manager's Office.

Stephen C. Bannon, Chair
Leigh Davis, Vice Chair
Eric Gabriel
Garfield C. Reed
Benjamin Elliott



Town Hall, 334 Main Street
Great Barrington, MA 01230

Telephone: (413) 528-1619 x2900
Fax: (413) 528-2290

TOWN OF GREAT BARRINGTON MASSACHUSETTS

SELECTBOARD

April 8, 2024

In honor of Earth Day, Saturday, April 20, 2024, we invite residents to participate in community cleanup efforts throughout Great Barrington and Housatonic.

Beginning Tuesday, April 16th, yellow and green bags for roadside trash pick-up will be available at the following locations:

- Claire Teague Senior Center – 915 S. Main St., Great Barrington
- Town Hall – 334 Main St., Great Barrington
- Mason Library – 231 Main St., Great Barrington
- Ramsdell Library – 1087 Main St., Housatonic
- Housatonic Post Office – 11 Depot St., Housatonic

Bags will be available on a first come first serve basis. More details on road cleanup sites will be available at pick-up locations and on the Town website in the coming days.

Please leave filled trash bags at a central location for pick-up by the Department of Public Works. Contact the Department of Public Works at: 413-528-0867 ext. 1 to let them know the location of your bags.

Special thanks to our Departments of Health and Public Works for coordinating these efforts.

SATURDAY, APRIL 20TH

HOUSATONIC

EARTH DAY

CLEANUP!



**CO-SPONSORED BY
HOUSATONIC THE
BEAUTIFUL & THE
HOUSATONIC
IMPROVEMENT
COMMITTEE**



**MEET AT RAMSDELL LIBRARY
AT 8:30AM; COFFEE &
PASTRIES PROVIDED, CLEANUP
TO BEGIN AT 9:00AM**



**CELEBRATORY BBQ TO FOLLOW
AT THE HOUSATONIC COMMONS
AT NOON**

CONTACT HOUSATONICTHEBEAUTIFUL@GMAIL.COM WITH ANY QUESTIONS